

PI-B Programmable Isolating Bridge Transmitter.

Programmable Isolating mV Bridge
Input to DC Current or
DC Voltage Output Transmitter.

Features.

- Field Programmable Input and Output Ranges.
- Bi-Polar Input and Output Ranges.
- Input to Output Isolation 1.6kV.
- High Accuracy 0.1%.
- Universal AC/DC Power Supply.
- Selectable 3 Second Input Damping.
- High Precision 10Vdc Bridge Power Supply.
- Compact DIN Rail Mount Enclosure.
- Available Standard or Special Calibration.

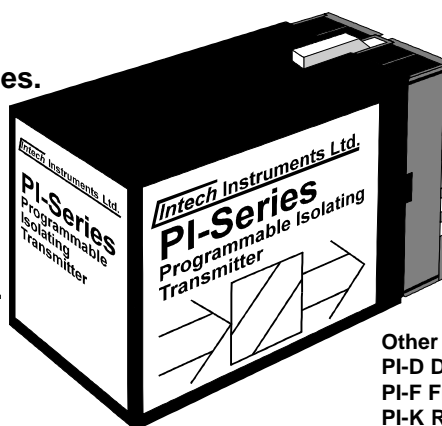

Other PI- models include:
PI-D DC;
PI-F Frequency;
PI-K Resistance;
PI-M Maths Computing;
PI-N RTD Differential Pt100;
PI-P Potentiometer;
PI-R RTD Pt100;
PI-S Dual Setpoint Controller;
PI-T Thermocouple.

Ordering Information.

PI-B-X Standard Calibration: Input 0~20mV; Output 4~20mA;
High Voltage Power Supply.

PI-B - - - - Special Range Special Range Calibration.
IR OR PS

INPUT RANGES				OUTPUT RANGES			
mV	IR	mV	IR	Voltage	OR	Current	OR
0~1mV	1	0~200mV	21	0~500mV	A	0~1mA	1
0~2mV	2	0~500mV	22	0~1V	B	0~2mA	2
0~3mV	3	0~750mV	23	0~2V	C	0~5mA	3
0~4mV	4	0~1000mV	24	0~3V	D	0~10mA	4
0~5mV	5	2~6mV	25	0~4V	E	0~16mA	5
0~6mV	6	5~10mV	26	0~5V	F	0~20mA	6
0~8mV	7	15~20mV	27	0~6V	G	1~5mA	7
0~10mV	8	30~35mV	28	0~8V	H	2~10mA	8
0~12mV	9	30~40mV	29	0~10V	I	4~20mA	9
0~15mV	10	30~45mV	30	0~12V	J	-1~1mA	10
0~20mV	11	30~60mV	31	1~5V	K	-2~2mA	11
0~25mV	12	50~80mV	32	2~10V	L	-5~5mA	12
0~30mV	13	100~200mV	33	-1~1V	M	-10~10mA	13
0~35mV	14	-2~4mV	34	-2~2V	N	-20~20mA	14
0~40mV	15	-4~6mV	35	-5~5V	O		
0~50mV	16	-5~7mV	36	-10~10V	P		
0~60mV	17	-10~20mV	37	-12~12V	Q		
0~75mV	18	-50~70mV	38				
0~80mV	19	-100~300mV	39				
0~100mV	20	-200~800mV	40				
Special Input Range			Z	Special Output Range			Z

POWER SUPPLY	PS
High Voltage Power Supply: 70~270Vac and 80~380Vdc	H
Mid Voltage Power Supply: 24~80Vac and 20~90Vdc	M
Low Voltage Power Supply: 8~30Vac and 8~30Vdc	L

Note: Power supply H is field selectable for M, and M for H. Power supply L must be ordered separately.

Ordering Examples.

- 1/ PI-B-8-1-L 0~10mV Input; 0~1mA Output; Low Voltage Power Supply
- 2/ PI-B-Z-P-H-0~18mV 0~18mV Input; -10~10V Output; High Voltage Power Supply

Quality Assurance Programme.

The modern technology and strict procedures of the ISO9001 Quality Assurance Programme applied during design, development, production and final inspection grant the long term reliability of the instrument.

PI-B Specifications.

Input	-MilliVolts	Field Programmable From 1mVdc to 1000mVdc and Bipolar. Minimum Input Resistance = 1M Ω .
		Maximum Over-range = 30Vdc Continuous.
		3 Second Input Damping Selectable with S5-1.
	-Bridge P/S	10Vdc \pm 0.1%. Max Load = 30mA. Ripple < 10mV Typical at 30mA Load.
Output	-Voltage	Field Programmable From 500mVdc to \pm 12Vdc. Maximum Output Drive = 10mA.
	-Current	Field Programmable From 1mAdc to \pm 20mAdc. Maximum Output Drive = 10Vdc. (500 Ω @ 20mA.)
Universal P/S	-Standard High (H)	70~270Vac and 80~380Vdc; 50/60Hz; 4VA.
	-Standard Mid (M)	24~80Vac and 20~90Vdc; 50/60Hz; 4VA.
	-Low Voltage (L)	8~30Vac and 8~30Vdc; 50/60Hz; 4VA.
	-Circuit Sensitivity	< \pm 0.001%/V FSO Typical.
Accurate to		< \pm 0.1% FSO Typical.
Linearity & Repeatability		< \pm 0.1% FSO Typical.
Ambient Drift		< \pm 0.01%/C FSO Typical.
Noise Immunity		125dB CMRR Average. (1.6kV Peak Limit.)
R.F. Immunity		<1% Effect FSO Typical.
Isolation Voltage		1.6kVac/dc Peak Input to Output for 60sec.
Response Time		200msec Typical. (10 to 90% 50msec Typical.)
Operating Temperature		0~70C.
Storage Temperature		-20~80C.
Operating Humidity		90% RH Max. Non-Condensing.
Construction		Socket Plug-In Type With Barrier Terminals.

Note 1. Specifications based on Standard Calibration Unit, unless otherwise specified.

Note 2. Due to ongoing research and development, designs, specifications, and documentation are subject to change without notification.

No liability will be accepted for errors, omissions or amendments to this specification.

Note 3. Further ranging and installation information supplied with each unit, and is available upon request.

Examples of Input Connection.

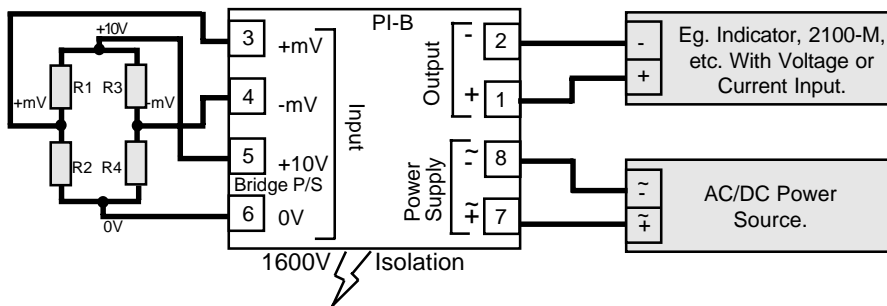

Terminations.

Output 1	+Ve
2	-Ve
Input 3	+mV
4	-mV
5	10V Bridge P/S
6	0V Bridge P/S
P/S 7	~AC/+DC
8	~AC/-DC

Dimensions and Mounting.

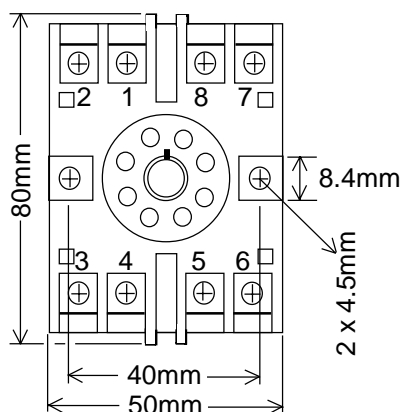

8PFA Octal Termination Base

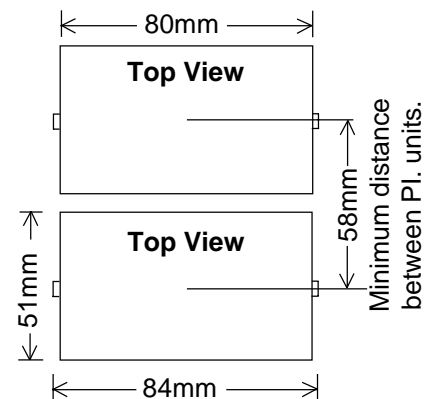
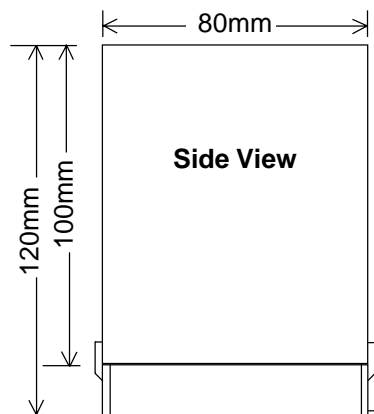

PI-S Programmable Isolating Dual Set Point Alarm Unit.

Programmable Isolating DC Voltage or DC Current Input Dual Setpoint Alarm Unit.

Features.

- Field Programmable Input Ranges.
- Isolated Input to Output 1.6kV.
- High Accuracy.
- Universal AC/DC Power Supply.
- 0~100% Alarm Set Point Range.
- Dual Relay or SSR Drive Outputs.
- LED Indication of Relay Status.
- N.O. / N.C. Selectable Contacts.
- 0.2~30sec Adjustable Delay.
- High, Low, Window & Differential Selectable Alarms.



Other PI- models include:
 PI-B Bridge / Strain gauge;
 PI-D DC;
 PI-F Frequency;
 PI-K Resistance;
 PI-M Maths Computing;
 PI-N RTD Differential Pt100;
 PI-P Potentiometer;
 PI-R RTD Pt100;
 PI-T Thermocouple.

Ordering Information.

PI-S-X Standard Calibration. Input: 4~20mA; Output: Relay A- High Alarm; Setpoint 80%; Relay B- Low Alarm; Setpoint 20%; Relay Contacts N.O.; No Time Delay; High Voltage Power Supply.

PI-S - - - -
 IR AR CO PS

Note: (i) N.O. = Normally Open, N.C. = Normally Closed.
 (ii) Differential is also known as 'PUMP ON / OFF'.

Input Ranges		Alarm Relay Action			Contact Options				
Range	IR	Relay A	Relay B	AR	Relay		SSR		CO
					A	B	A	B	
0~5V	1	High Alarm	High Alarm	A	N.O.	N.O.			1
1~5V	2	High Alarm	Low Alarm	B	N.O.	N.C.			2
0~10V	3	High Alarm	Slave Without Delay	C	N.C.	N.O.			3
2~10V	4	High Alarm	Slave With Delay	D	N.C.	N.C.			4
0~10mA	5	High Alarm	Inverted Slave With Delay	E			N.O.	N.O.	5
2~10mA	6	Low Alarm	High Alarm	F			N.O.	N.C.	6
0~20mA	7	Low Alarm	Low Alarm	G			N.C.	N.O.	7
4~20mA	8	Low Alarm	Slave Without Delay	H			N.C.	N.C.	8
0~50mA	9	Low Alarm	Slave With Delay	I					
10~50mA	10	Low Alarm	Inverted Slave With Delay	J					
		Window Comparator	High Alarm	K					
		Window Comparator	Low Alarm	L					
		Window Comparator	Slave Without Delay	M					
		Window Comparator	Slave With Delay	N					
		Window Comparator	Inverted Slave With Delay	O					
		Differential	High Alarm	P					
		Differential	Low Alarm	Q					
		Differential	Slave Without Delay	R					
		Differential	Slave With Delay	S					
Special Input Range	Z	Differential	Inverted Slave With Delay	T					
Power Supply									PS
High Voltage Power Supply: 70~270Vac and 80~380Vdc									H
Mid Voltage Power Supply: 24~80Vac and 20~90Vdc									M
Low Voltage Power Supply: 8~30Vac and 8~30Vdc									L

Note: Power supply H is field selectable for M, and M for H. Power supply L must be ordered separately.

Ordering Examples:

- 1/ PI-S-3-A-4-H 0~10V Input; High Alarms; N.C. Contacts; High Voltage Power Supply.
- 2/ PI-S-8-M-1-H 4~20mA Input; Window With Slave; N.O. Contacts; High Voltage Power Supply.

Quality Assurance Programme.

The modern technology and strict procedures of the ISO9001 Quality Assurance Programme applied during design, development, production and final inspection grant the long term reliability of the instrument.

PI-S Specifications.

Input	-Voltage	Field Programmable 0~5, 1~5, 0~10 & 2~10Vdc. Minimum Input Resistance = 200kΩ. Maximum Over Range = 200Vdc Continuous.
	- Current	Field Programmable 0~10, 2~10, 0~20, 4~20, 0~50 & 10~50mA. Maximum Input Resistance 20mA Ranges = 50Ω, Other mA Ranges = 100Ω. Maximum Over Range = 80mAadc Continuous.
Output	-Both Relays	Field Selectable, N.O. or N.C. Field Selectable; Active on High or Low; Window Alarm; or Differential Alarm.
	-SSR Drive	12V @ 20mA max.
Alarm Setting Range		0~100% of Input Signal: 0~99% in 1% Increments, Using Two Ten-position Setpoint Switches and ±1% Using the Fine Adjustment Trimpot.
Alarm Hysteresis		1% FSO Typical.
Time Delay		0.2~30sec Nominal, Adjustable by a Single Turn Trimpot.
LED Indication		Operates When Alarms are Active.
Relays.	-Action	SPST.
	-Contact Material	Silver Alloy
	Rating	No. of Operations
	250Vac, 2A	2x10 ⁵
	125Vac, 2A	2x10 ⁵
	110Vdc, 0.3A	
	30Vdc, 2A	
	1/6hp, 250Vac	
	1/10hp, 125Vac	
Universal P/S	-Standard High (H)	70~270Vac and 80~380Vdc; 50/60Hz; 4VA.
	-Standard Mid (M)	24~80Vac and 20~90Vdc; 50/60Hz; 4VA.
	-Low Voltage (L)	8~30Vac and 8~30Vdc; 50/60Hz; 4VA.
	-Circuit Sensitivity	<±0.001%/V FSO Typical.
Accurate to:		<±0.1% FSO Typical.
Linearity & Repeatability		<±0.1% FSO Typical.
Ambient Drift		<±0.01%/C FSO Typical.
Noise Immunity		125dB CMRR Average. (1.6kV Peak Limit).
R.F. Immunity		<1% Effect FSO Typical.
Isolation Voltage		1.6kVac/dc Input to Output for 60sec.
Operating Temperature		0~70C.
Storage Temperature		-20~80C.
Operating Humidity		90%RH Max. Non-Condensing.
Construction		Socket Plug-In Type With Barrier Terminals.

Note 1. Specifications based on Standard Calibration Unit, unless otherwise specified.

Note 2. Due to ongoing research and development, designs, specifications, and documentation are subject to change without notification.

No liability will be accepted for errors, omissions or amendments to this specification.

Note 3. Further ranging and installation information supplied with each unit, and is available upon request.

Examples of Input Connection.

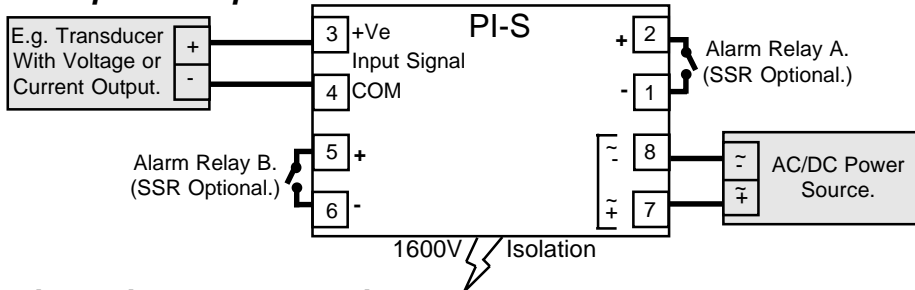

Terminations

Alarm A:	1	RELAY
	2	A
Input	3	+Ve SIGNAL
	4	COM
Alarm B:	5	RELAY
	6	B
P/S	7	~AC/+DC
	8	~AC/-DC

Dimensions and Mounting.

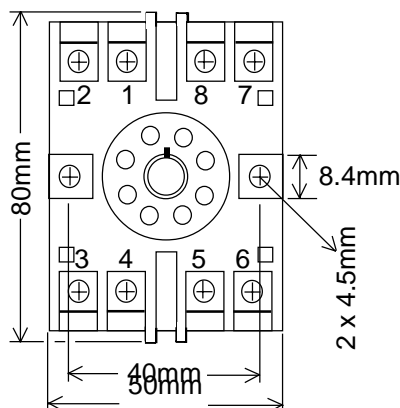

8PFA Octal Termination Base

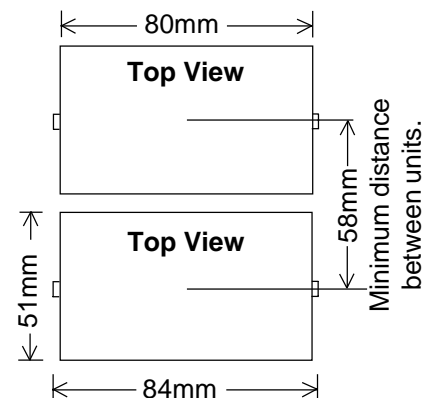
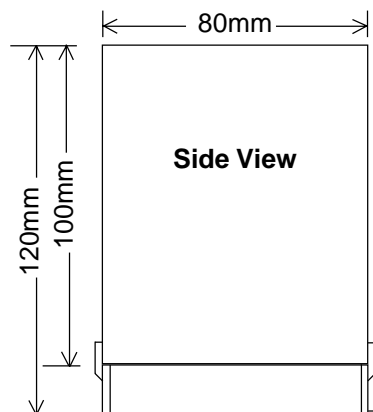

Intech INSTRUMENTS LTD.

Auckland: 09-8271930 Christchurch: 03-343 0646 Nelson: 03-546 6840

12.01-2

pi-s_2pg.p65
ISSUE 200999

PI-RAC, RS-232 Hardware Interface.

Hardware Interface for Connection
Between the PI-M and an RS-232
COMMS Port of a Computer Terminal.

Features of PI-RAC.

- Operates From Single PI-M 5Vdc Supply.
- Meets All RS-232 and V.28 Specifications.
- No Other Hardware Required.



The PI-RAC is a line driver / receiver, enabling communications between the PI-M and a computer terminal. This allows the PI-M to be tested and calibrated, and the PI-M-T to be programmed with a user defined curve. The PI-RAC has two DC/DC converters operating from the single 5V supply of the PI-M, generating $\pm 9V$ for RS-232 transmission.

The PI-RAC has a 0.5m cable and socket for direct connection to the PI-M, and is housed in a standard, 25 pin, RS-232, D-connector.

Specifications.

RS-232	-Input	$\pm 30V$ Max.
	-Output	$\pm 9V$ Typical.
	-Input Resistance	$7k\Omega$ Typical.
	-Output Current	$\pm 10mA$ Max.
Cable	-TTL (From PI-M)	0.5m Max. Supplied With PI-RAC.
	-RS-232	15m Max.

Note 1. Specifications based on Standard Calibration Unit, unless otherwise specified.

Note 2. Due to ongoing research and development, designs, specifications, and documentation are subject to change without notification.

No liability will be accepted for errors, omissions or amendments to this specification.

Ordering Information.

PI-RAC PI-M to RS-232 interface, complete with cable for direct connection to PI-M.

D Connector Pin Assignments.

Pin 2 - TD Data from PC.
Pin 3 - RD Data from PI-M.
Pin 4 - RTS Handshake from PC.
Pin 5 - CTS Handshake to PC.
Pin 6 - DSR Handshake to PC.
Pin 7 - GND Signal Ground.
Pin 8 - CD Handshake to PC.

NOTES: Pins 4 & 5 and pins 6 & 8 shorted internally.

Computer Setup.

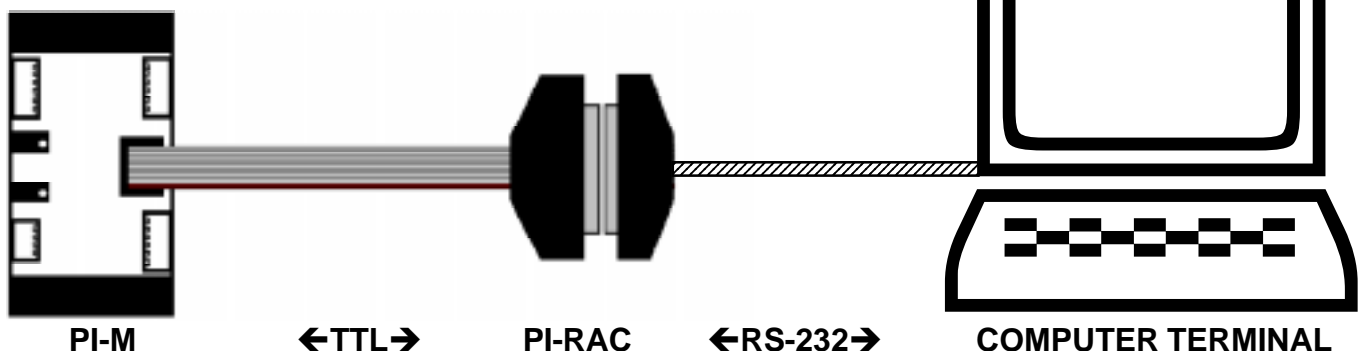

Quality Assurance Programme.

The modern technology and strict procedures of the ISO9001 Quality Assurance Programme applied during design, development, production and final inspection grant long term reliability of the instrument.

Intech INSTRUMENTS LTD.

Christchurch
Ph: 03 343 0646
Fx: 03 343 0649
6.02-1

Nelson
Ph: 03 546 6840
Fx: 03 548 8797

Auckland
Ph: 09 827 1930
Fx: 09 827 1931

pi-rac.p65
ISSUE 040799

PI-R Programmable Isolating RTD Transmitter.

Programmable, Isolating, 3 Wire RTD Input to DC Current or DC Voltage Output Transmitter.

Features.

- Field Programmable Input and Output Ranges.
- Bi-Polar Input and Output Ranges.
- Isolated Input to Output 1.6kV.
- High Accuracy & Linearity 0.1%.
- Linear With Temperature.
- Universal AC/DC Power Supply.
- Compact DIN Rail Mount Enclosure.
- Available Standard or Special Calibration.



Ordering Information.

PI-R-X Standard Calibration: Input 0~100C; Output 4~20mA; Upscale Break; High Voltage Power Supply.

PI-R - - - - - Special Range Calibration.
IR OR SB PS

Other types of RTD available in special range calibration are JIS Pt100, Pt250, Pt500, Pt1000, CU10, CU100, Ni100 or specify.

Other PI- models include:
PI-B Bridge / Strain gauge;
PI-D DC;
PI-F Frequency;
PI-K Resistance;
PI-M Maths Computing;
PI-N RTD Differential Pt100;
PI-P Potentiometer;
PI-S Dual Setpoint Controller;
PI-T Thermocouple.

INPUT RANGES (DIN PT100)								OUTPUT RANGES				Sensor Break	
deg C	IR	deg C	IR	deg F	IR	deg F	IR	Voltage	OR	Current	OR	State	SB
0~20C	1	-10~10C	21	0~40F	41	-20~20F	61	0~500mV	A	0~1mA	1	Upscale	US
0~25C	2	-10~20C	22	0~50F	42	-20~40F	62	0~1V	B	0~2mA	2	Downscale	DS
0~30C	3	-10~40C	23	0~60F	43	-20~80F	63	0~2V	C	0~5mA	3		
0~40C	4	-20~20C	24	0~80F	44	-40~40F	64	0~3V	D	0~10mA	4		
0~50C	5	-20~30C	25	0~100F	45	-40~60F	65	0~4V	E	0~16mA	5		
0~60C	6	-25~25C	26	0~120F	46	-50~50F	66	0~5V	F	0~20mA	6		
0~70C	7	-25~50C	27	0~140F	47	-50~100F	67	0~6V	G	1~5mA	7		
0~75C	8	-30~20C	28	0~150F	48	-60~40F	68	0~8V	H	2~10mA	8		
0~80C	9	-50~50C	29	0~160F	49	-100~100F	69	0~10V	I	4~20mA	9		
0~90C	10	-50~100C	30	0~180F	50	-100~200F	70	0~12V	J	-1~1mA	10		
0~100C	11	-50~150C	31	0~200F	51	-100~300F	71	1~5V	K	-2~2mA	11		
0~110C	12	-100~100C	32	0~220F	52	-200~200F	72	2~10V	L	-5~5mA	12		
0~120C	13	-100~200C	33	0~240F	53	-200~400F	73	-1~1V	M	-10~10mA	13		
0~125C	14	-200~200C	34	0~250F	54	-400~400F	74	-2~2V	N	-20~20mA	14		
0~150C	15	-200~400C	35	0~300F	55	-400~800F	75	-5~5V	O				
0~200C	16	20~40C	36	0~400F	56	40~80F	76	-10~10V	P				
0~250C	17	50~100C	37	0~500F	57	100~200F	77	-12~12V	Q				
0~300C	18	50~150C	38	0~600F	58	100~300F	78						
0~400C	19	100~200C	39	0~800F	59	200~400F	79						
0~600C	20	100~500C	40	0~1200F	60	200~1000F	80						
Special Input Range			Z	Special Input Range			Z	Special Output Range			Z		

POWER SUPPLY		PS
High Voltage Power Supply: 70~270Vac and 80~380Vdc		H
Mid Voltage Power Supply: 24~80Vac and 20~90Vdc		M
Low Voltage Power Supply: 8~30Vac and 8~30Vdc		L

Note: Power supply H is field selectable for M, and M for H. Power supply L must be ordered separately.

Ordering Examples.

- 1/ PI-R-5-1-L 0~50C In; 0~1mA Out; Upscale Break; Low Voltage Power Supply.
- 2/ PI-R-Z-P-H-CU10-0/150C CU10 0~150C In; -10~10V Out; Upscale Break; High Voltage Power Supply.

Quality Assurance Programme.

The modern technology and strict procedures of the ISO9001 Quality Assurance Programme applied during design, development, production and final inspection grant long term reliability of the instrument.

PI-R Specifications.

RTD Input		Pt100 DIN (3 Wire Type) Standard. Sensor Current = 0.8mA Typical. Lead Wire Resistance = 10Ω/Wire Max. Field Programmable Zero From -200C(-400F) to 200C(400F). Field Programmable Span From 20C(40F) to 600C(1200F). Suitable for 2 Wire Connection. (Offset Calibration Needed.) Other Types of RTD Available. JIS Pt100, Pt250, Pt500, Pt1000, CU10, CU100, Ni100 or Specify.
Output	- Voltage	Field Programmable From 500mVdc to ±12Vdc. Maximum Output Drive = 10mA.
	- Current	Field Programmable From 1mA dc to ±20mA dc. Maximum Output Drive = 10Vdc. (500Ω @ 20mA.)
Universal P/S	-Standard High (H)	70~270Vac and 80~380Vdc; 50/60Hz; 4VA.
	-Standard Mid (M)	24~80Vac and 20~90Vdc; 50/60Hz; 4VA.
	-Low Voltage (L)	8~30Vac and 8~30Vdc; 50/60Hz; 4VA.
	-Circuit Sensitivity	<±0.001%/V FSO Typical.
Accurate to		<±0.1% FSO Typical.
Linearity & Repeatability		<±0.1% FSO Typical.
Ambient Drift		<±0.01%/C FSO Typical.
Noise Immunity		125dB CMRR Average. (1.6kV Peak Limit.)
R.F. Immunity		<1% Effect FSO Typical.
Isolation Voltage		1.6kVac/dc Input to Output for 60sec.
Response Time		200msec Typical. (10 to 90% 50msec Typical.)
Operating Temperature		0~70C.
Storage Temperature		-20~80C.
Operating Humidity		90% RH Max. Non-Condensing.
Construction		Socket Plug-In Type With Barrier Terminals.

Note 1. Specifications based on Standard Calibration Unit, unless otherwise specified.

Note 2. Due to ongoing research and development designs, specifications, and documentation are subject to change without notification.

No liability will be accepted for errors, omissions or amendments to this specification.

Note 3. Further ranging and installation information supplied with each unit, and is available upon request.

Examples of Input Connection.

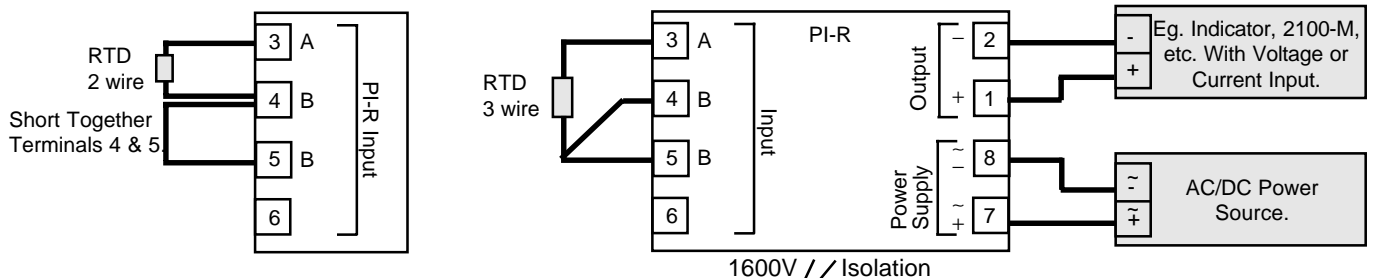

Terminations.

Output	1	+Ve
	2	-Ve
P/S	7	~AC/+DC
	8	~AC/-DC

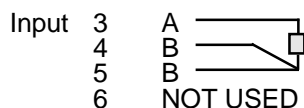

Dimensions and Mounting.

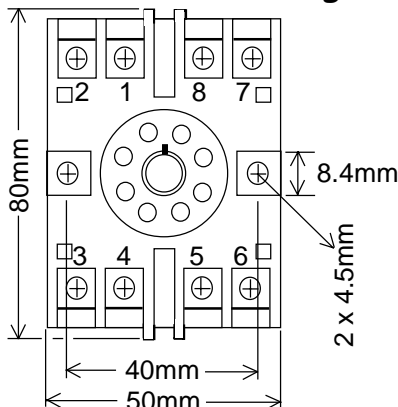

8PFA Octal Termination Base

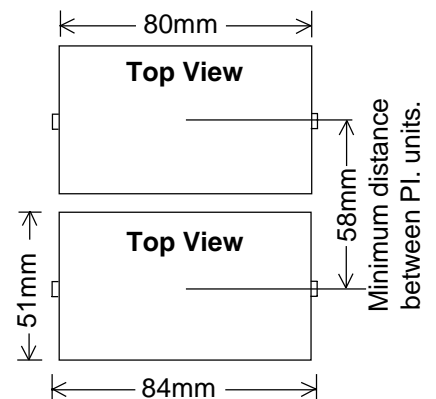
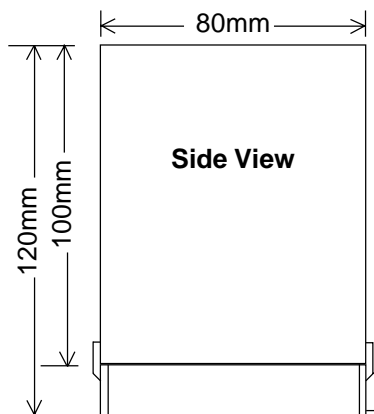

PI-P Programmable Isolating Potentiometer Transmitter.

Programmable Isolating 3 Wire Potentiometer Input to DC Current or DC Voltage Output Transmitter.

Features.

- Field Programmable Input and Output Ranges.
- Bi-Polar Output Ranges.
- Isolated Input to Output 1.6kV.
- High Accuracy 0.1%.
- Universal AC/DC Power Supply.
- Compact DIN Rail Mount Enclosure.
- Available Standard or Special Calibration.

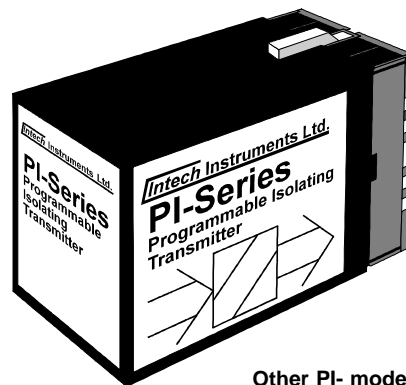

Ordering Information.

PI-P-X Standard Calibration: Input 0~100%; Output 4~20mA; High Voltage Power Supply.

PI-P - IR - OR - PS - Special Range Special Range Calibration.

Other PI- models include:
 PI-B Bridge / Strain gauge;
 PI-D DC;
 PI-F Frequency;
 PI-K Resistance;
 PI-M Maths Computing;
 PI-N RTD Differential Pt100;
 PI-R RTD Pt100;
 PI-S Dual Setpoint Controller;
 PI-T Thermocouple.

INPUT RANGE (% of POTENTIOMETER.)				OUTPUT RANGES			
%POT	IR	%POT	IR	Voltage	OR	Current	OR
0~10%	1	20~40%	16	0~500mV	A	0~1mA	1
0~15%	2	40~60%	17	0~1V	B	0~2mA	2
0~20%	3	60~80%	18	0~2V	C	0~5mA	3
0~25%	4	80~100%	19	0~3V	D	0~10mA	4
0~30%	5	25~50%	20	0~4V	E	0~16mA	5
0~33%	6	50~75%	21	0~5V	F	0~20mA	6
0~40%	7	75~100%	22	0~6V	G	1~5mA	7
0~50%	8	33~67%	23	0~8V	H	2~10mA	8
0~60%	9	67~100%	24	0~10V	I	4~20mA	9
0~67%	10	50~100%	25	0~12V	J	-1~1mA	10
0~70%	11	10~90%	26	1~5V	K	-2~2mA	11
0~75%	12	20~80%	27	2~10V	L	-5~5mA	12
0~80%	13	25~75%	28	-1~1V	M	-10~10mA	13
0~90%	14	30~70%	29	-2~2V	N	-20~20mA	14
0~100%	15	40~60%	30	-5~5V	O		
				-10~10V	P		
				-12~12V	Q		
Special Input Calibration Range			Z	Special Output Calibration Range			Z

POWER SUPPLY	PS
High Voltage Power Supply: 70~270Vac and 80~380Vdc	H
Mid Voltage Power Supply: 24~80Vac and 20~90Vdc	M
Low Voltage Power Supply: 8~30Vac and 8~30Vdc	L

Note: Power supply H is field selectable for M, and M for H. Power supply L must be ordered separately.

Ordering Examples.

- 1/ PI-P-8-1-L 0~50% Input; 0~1mA Output; Low Voltage Power Supply.
- 2/ PI-P-Z-P-H-0/28 0~28% Input; -10~10V Output; High Voltage Power Supply.

Quality Assurance Programme.

The modern technology and strict procedures of the ISO9001 Quality Assurance Programme applied during design, development, production and final inspection grant long term reliability of the instrument.

PI-P Specifications.

Potentiometer Input		3 Wire Potentiometer. Excitation Voltage = 2.5Vdc. Minimum Potentiometer Resistance = 200Ω. Maximum Potentiometer Resistance = 1MΩ. Field Programmable Zero From 0 to 100%. Field Programmable Span From 0 to 100%.
Output	-Voltage	Field Programmable From 500mV to ±12Vdc. Maximum Output Drive = 10mA.
	-Current	Field Programmable From 1 mAdc to ±20mAdc. Maximum Output Drive = 10Vdc. (500Ω @ 20mA.)
Universal P/S	-Standard High (H)	70~270Vac and 80~380Vdc; 50/60Hz; 4VA.
	-Standard Mid (M)	24~80Vac and 20~90Vdc; 50/60Hz; 4VA.
	-Low Voltage (L)	8~30Vac and 8~30Vdc; 50/60Hz; 4VA.
	-Circuit Sensitivity	<±0.001%/V FSO Typical.
Accurate to		<±0.1% FSO Typical.
Linearity & Repeatability		<±0.1% FSO Typical.
Ambient Drift		<±0.01%/C FSO Typical.
Noise Immunity		125dB CMRR Average. (1.6kV Peak Limit.)
R.F. Immunity		<1% Effect FSO Typical.
Isolation Voltage		1.6kVac/dc Peak Input to Output for 60sec.
Response Time		200msec Typical. (10 to 90% 50msec Typical.)
Operating Temperature		0~70C.
Storage Temperature		-20~80C.
Operating Humidity		90% RH Max. Non-Condensing.
Construction		Socket Plug-In Type With Barrier Terminals.

Note 1. Specifications based on Standard Calibration Unit, unless otherwise specified.

Note 2. Due to ongoing research and development, designs, specifications, and documentation are subject to change without notification.

No liability will be accepted for errors, omissions or amendments to this specification.

Note 3. Further ranging and installation information supplied with each unit, and is available upon request.

Examples of Input Connection.

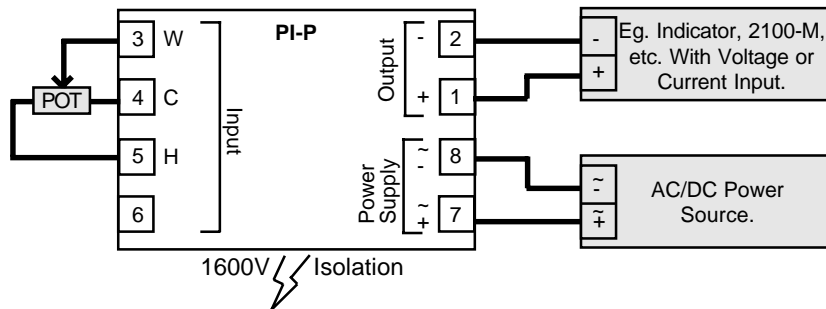

Terminations.

Output	1	+Ve	Input	3	WIPER
	2	-Ve		4	COM
				5	HIGH
P/S	7	~AC/+DC		6	NOT USED
	8	~AC/-DC			

Dimensions and Mounting.

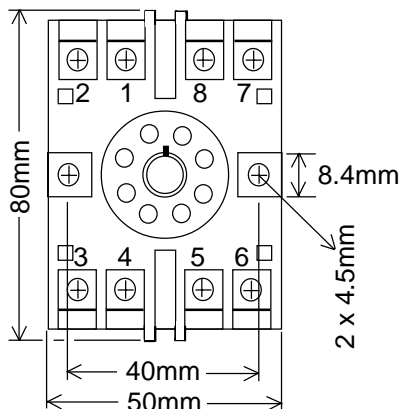

8PFA Octal Termination Base

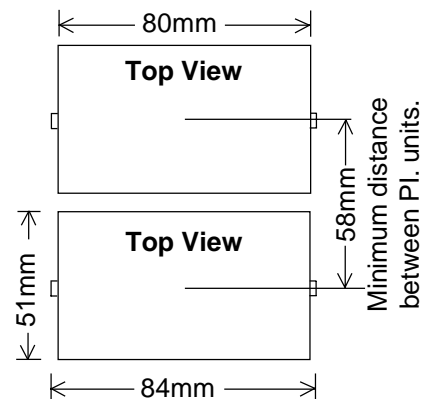
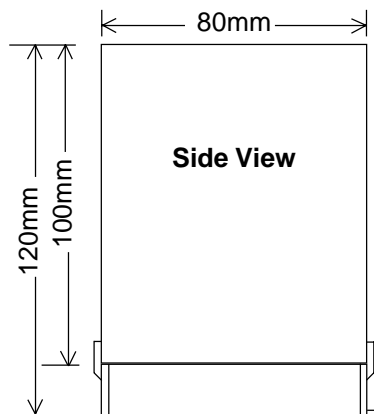

Intech INSTRUMENTS LTD.

Christchurch
Ph: 03 343 0646
Fx: 03 343 0649
8.04-2

Nelson
Ph: 03 546 6840
Fx: 03 548 8797

Auckland
Ph: 09 827 1930
Fx: 09 827 1931

pi-p_2pg.p65
ISSUE 200999

PI-N Programmable Isolating Differential RTD Transmitter.

Programmable Isolating Differential 2 Wire RTD Input to DC Current or DC Voltage Output Transmitter.

Features.

- Field Programmable Input and Output Ranges.
- Bi-Polar Input and Output Ranges.
- Isolated Input to Output 1.6kV.
- High Accuracy & Linearity to 0.1%.
- Linear With Temperature.
- Universal AC/DC Power Supply.
- Compact DIN Rail Mount Enclosure.
- Available Standard or Special Calibration.

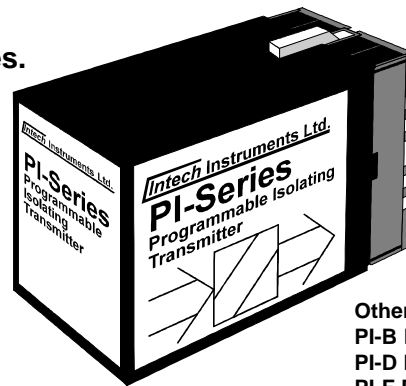

Other PI- models include:
 PI-B Bridge / Strain gauge;
 PI-D DC;
 PI-F Frequency;
 PI-K Resistance;
 PI-M Maths Computing;
 PI-P Potentiometer;
 PI-R RTD Pt100;
 PI-S Dual Setpoint Controller;
 PI-T Thermocouple.

Ordering Information.

PI-N-X Standard Calibration: Input 0~100C; Output 4~20mA; Upscale Break; High Voltage Power Supply.

PI-N - - - - - Special Range Calibration.
 IR OR SB PS

Other types of RTD available in special range calibration are JIS Pt100, Pt250, Pt500, Pt1000, CU10, CU100, Ni100 or specify.

INPUT RANGES (DIN PT100)								OUTPUT RANGES				Sensor Break	
deg C	IR	deg C	IR	deg F	IR	deg F	IR	Voltage	OR	Current	OR	State	SB
0~20C	1	-10~10C	21	0~40F	41	-20~20F	61	0~500mV	A	0~1mA	1	Upscale	US
0~25C	2	-10~20C	22	0~50F	42	-20~40F	62	0~1V	B	0~2mA	2	Downscale	DS
0~30C	3	-10~40C	23	0~60F	43	-20~80F	63	0~2V	C	0~5mA	3		
0~40C	4	-20~20C	24	0~80F	44	-40~40F	64	0~3V	D	0~10mA	4		
0~50C	5	-20~30C	25	0~100F	45	-40~60F	65	0~4V	E	0~16mA	5		
0~60C	6	-25~25C	26	0~120F	46	-50~50F	66	0~5V	F	0~20mA	6		
0~70C	7	-25~50C	27	0~140F	47	-50~100F	67	0~6V	G	1~5mA	7		
0~75C	8	-30~20C	28	0~150F	48	-60~40F	68	0~8V	H	2~10mA	8		
0~80C	9	-50~50C	29	0~160F	49	-100~100F	69	0~10V	I	4~20mA	9		
0~90C	10	-50~100C	30	0~180F	50	-100~200F	70	0~12V	J	-1~1mA	10		
0~100C	11	-50~150C	31	0~200F	51	-100~300F	71	1~5V	K	-2~2mA	11		
0~110C	12	-100~100C	32	0~220F	52	-200~200F	72	2~10V	L	-5~5mA	12		
0~120C	13	-100~200C	33	0~240F	53	-200~400F	73	-1~1V	M	-10~10mA	13		
0~125C	14	-200~200C	34	0~250F	54	-400~400F	74	-2~2V	N	-20~20mA	14		
0~150C	15	-200~400C	35	0~300F	55	-400~800F	75	-5~5V	O				
0~200C	16	20~40C	36	0~400F	56	40~80F	76	-10~10V	P				
0~250C	17	50~100C	37	0~500F	57	100~200F	77	-12~12V	Q				
0~300C	18	50~150C	38	0~600F	58	100~300F	78						
0~400C	19	100~200C	39	0~800F	59	200~400F	79						
0~600C	20	100~500C	40	0~1200F	60	200~1000F	80						
Special Input Range			Z	Special Input Range			Z	Special Output Range			Z		

POWER SUPPLY		PS
High Voltage Power Supply: 70~270Vac and 80~380Vdc		H
Mid Voltage Power Supply: 24~80Vac and 20~90Vdc		M
Low Voltage Power Supply: 8~30Vac and 8~30Vdc		L

Note: Power supply H is field selectable for M, and M for H. Power supply L must be ordered separately.

Ordering Examples.

- 1/ PI-N-5-1-L 0~50C Input; 0~1mA Out; Upscale Break; Low Voltage Power Supply.
 2/ PI-N-Z-P-H-CU10-0/150C CU10 0~150C In; -10~10V Out; Upscale Break; High Voltage Power Supply.

Quality Assurance Programme.

The modern technology and strict procedures of the ISO9001 Quality Assurance Programme applied during design, development, production and final inspection grant long term reliability of the instrument.

PI-N Specifications.

RTD Input		Pt100 DIN (2 Wire Type) Standard. Sensor Current = 0.8mA Typical. Field Programmable Zero From -200C(-400F) to 200C(400F). Field Programmable Span From 20C(40F) to 600C(1200F). Other Types of RTD Available: JIS Pt100, Pt250, Pt500, Pt1000, CU10, CU100, Ni100 or Specified.
Output	- Voltage	Field Programmable From 500mVdc to ±12Vdc. Maximum Output Drive = 10mA.
	- Current	Field Programmable From 1mA to ±20mA. Maximum Output Drive = 10Vdc. (500Ω @ 20mA.)
Universal P/S	-Standard High (H)	70~270Vac and 80~380Vdc; 50/60Hz; 4VA.
	-Standard Mid (M)	24~80Vac and 20~90Vdc; 50/60Hz; 4VA.
	-Low Voltage (L)	8~30Vac and 8~30Vdc; 50/60Hz; 4VA.
	-Circuit Sensitivity	<±0.001%/V FSO Typical.
Accurate to		<±0.1% FSO Typical.
Linearity & Repeatability		<±0.1% FSO Typical.
Ambient Drift		<±0.01%/C FSO Typical.
Noise Immunity		125dB CMRR Average. (1.6kV Peak Limit.)
R.F. Immunity		<1% Effect FSO Typical.
Isolation Voltage		1.6kVac/dc Input to Output for 60 sec.
Response Time		200msec Typical. (10 to 90% 50msec Typical.)
Operating Temperature		0~70C.
Storage Temperature		-20~80C.
Operating Humidity		90% RH Max. Non-Condensing.
Construction		Socket Plug-In Type with Barrier Terminals.

Note 1. Specifications based on Standard Calibration Unit, with RTD 2 at 0C, unless otherwise specified.

Note 2. Due to ongoing research and development designs, specifications, and documentation are subject to change without notification.

No liability will be accepted for errors, omissions or amendments to this specification.

Note 3. Further ranging and installation information supplied with each unit, and is available upon request.

Examples of Input Connection.

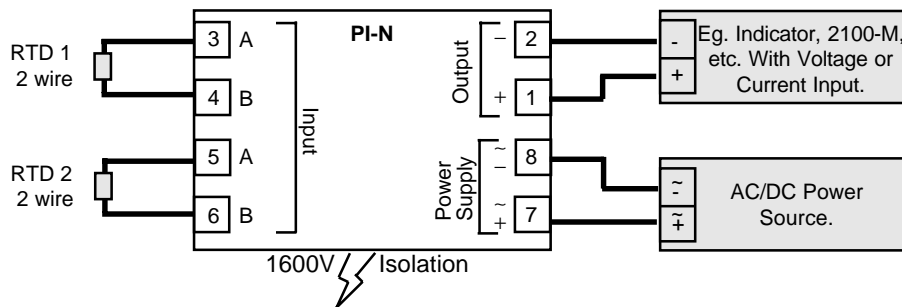

Terminations.

Output	1	+Ve	Input	3	A	RTD 1
	2	-Ve		4	B	
P/S	7	~AC/+DC		5	A	RTD 2
	8	~AC/-DC		6	B	

Dimensions and Mounting.

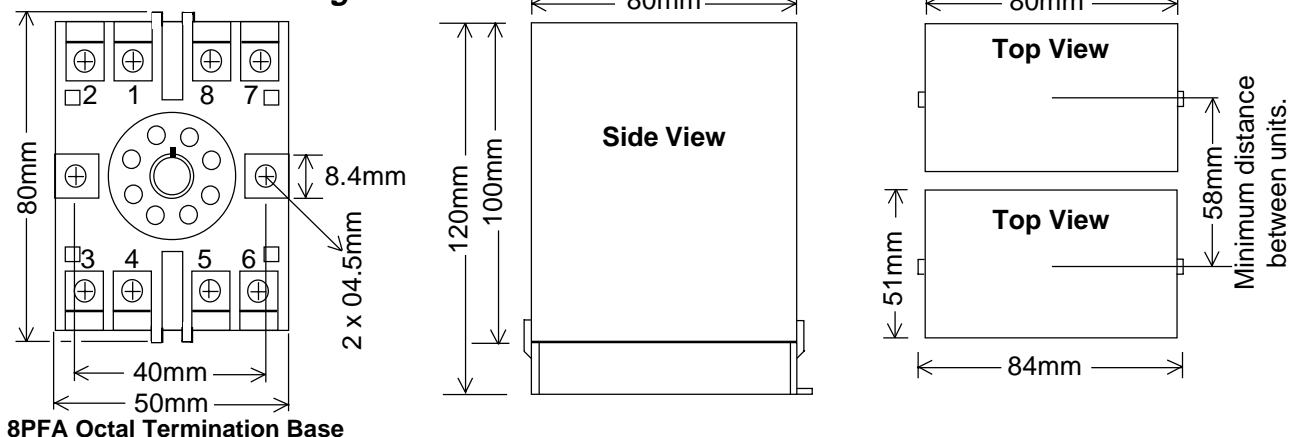

PI-M Programmable Isolating Maths Function Transmitter.

Programmable Isolating Maths Function Input to DC Current or DC Voltage Output Transmitter.

Features.

- Field Programmable Input and Output Ranges.
- 29 Predefined Math Functions.
- 12 Bit Resolution. (0.025%)
- Input to Output Isolation 1.6kV.
- High Accuracy 0.1%.
- Universal AC/DC Power Supply.
- Compact DIN Rail Mount Enclosure.
- 120 Point User Definable Curve Fitting.

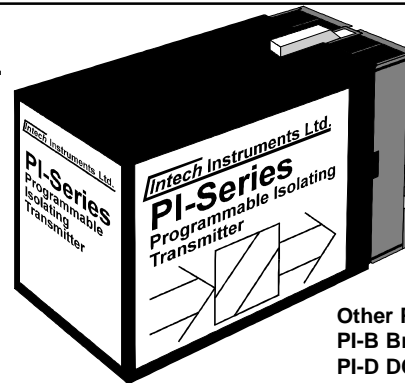

Ordering Information.

PI-M-X Standard Calibration: Input 4~20mA; X+Y; Output 4~20mA High Voltage Power Supply.

PI-M - - - - -Special Range Special Range Calibration.
IR MF OR PS

PI-RAC RS-232 Hardware Interface for Programming the PI-M-T.

Other PI- models include:
PI-B Bridge / Strain gauge;
PI-D DC;
PI-F Frequency;
PI-K Resistance;
PI-N Differential Pt100 RTD;
PI-P Potentiometer;
PI-R Pt100 RTD;
PI-S Dual Setpoint Controller;
PI-T Thermocouple;

INPUT RANGES		MATHS FUNCTION				OUTPUT RANGES				
Input	IR	Maths Funct. (Output =)	MF	Maths Funct. (Output =)	MF	Voltage	OR	Current	OR	
0~5V	A	X + Y	1	Sample and Hold	26	0~500mV	A	0~1mA	1	
0~10V	B	X + Y + Z	2	Tare	27	0~1V	B	0~2mA	2	
1~5V	C	X - Y	3		28	0~2V	C	0~5mA	3	
2~10V	D	X - Y + Z	4	%RH, X=Dry, Y=Wet	29	0~3V	D	0~10mA	4	
0~20mA	E	X x Y	5	User Defined Curve	30	0~4V	E	0~16mA	5	
4~20mA	F	X x Y x Z	6	Program User Defined Curve	31	0~5V	F	0~20mA	6	
		X / Y	7	Pressure Comp. Steam Flow	32	0~6V	G	1~5mA	7	
		(X / Y) x Z	8	Program PCSF Values	33	0~8V	H	2~10mA	8	
		X^(1/2) {Square root X}	9	Hi Select of X or Y	34	0~10V	I	4~20mA	9	
		X^(1/3) {Cube root X}	10	Lo Select of X or Y	35	0~12V	J	-1~1mA	10	
		X^(2/3)	11		36	1~5V	K	-2~2mA	11	
		X ²	12		37	2~10V	L	-5~5mA	12	
		X ³	13		38	-1~1V	M	-10~10mA	13	
		ln X {Natural log X}	14		39	-2~2V	N	-20~20mA	14	
		log X {Base 10 log X}	15		40	-5~5V	O			
		(X ² + Y ²)^(1/2)	16		41	-10~10V	P			
		(X + Y) / 2	17		42	-12~12V	Q			
		(X + Y + Z) / 3	18		43					
		X^1.569 {Parshall Flume}	19		44					
		X^(2/3) {V Notch Weir}	20		45					
		X {ie Xin=Xout}	21		46					
		Inverse of X {ie.(100-X)%}	22		47					
		X / (X + Y)	23		48					
		Antilog X	24		49					
		(X - Y) x Z	25		50					
Special Input	Z					Special Output Range				Z

Note: Hi Select and Lo Select available from S/No. 9844000 onwards.

POWER SUPPLY		PS
High Voltage Power Supply: 70~270Vac and 80~380Vdc		H
Mid Voltage Power Supply: 24~80Vac and 20~90Vdc		M
Low Voltage Power Supply: 8~30Vac and 8~30Vdc		L

Note: Power supply H is field selectable for M, and M for H. Power supply L must be ordered separately.

Ordering Examples.

- 1/ PI-M-A-3-9-L 0~5V Input; X-Y; 4~20mA Output; Low Voltage Power Supply.
- 2/ PI-M-Z-7-P-H-0/4V 0~4V Input; X/Y; -10~10V Output; High Voltage Power Supply.

Quality Assurance Programme.

The modern technology and strict procedures of the ISO9001 Quality Assurance Programme applied during design, development, production and final inspection grant the long term reliability of the instrument.

PI-M Specifications.

Input	-Voltage	Field Programmable 0~5Vdc / 0~10Vdc / 1~5Vdc / 2~10Vdc. Minimum Input Resistance = 180kΩ.
	-Current	Maximum Over-range = 24Vdc Continuous. Field Programmable 0~20mAdc / 4~20mAdc. Input Resistance = 250Ω. Maximum Over-range = 50mAdc Continuous.
	-Maths Functions	29 Field Selectable, Predefined, Maths Functions.
	-User Defined Curve	Up to 120 Point Look-up Table, Linear Interpolation Between Points. RS-232 Interface for Calibration and Testing. (Using a PI-RAC.) RS-232 Interface for Programming of User Curves. (Using a PI-RAC.)
IMPORTANT: The RS-232 communications port is NOT ISOLATED from the PI-M inputs.		
Universal P/S	-Standard High (H)	70~270Vac and 80~380Vdc; 50/60Hz; 4VA.
	-Standard Mid (M)	24~80Vac and 20~90Vdc; 50/60Hz; 4VA.
	-Low Voltage (L)	8~30Vac and 8~30Vdc; 50/60Hz; 4VA.
	-Circuit Sensitivity	<±0.001%/V FSO Typical.
Resolution	-Input	12 Bit.
	-Output	12 Bit.
Accurate to		<±0.1% FSO Typical.
Linearity & Repeatability		<±0.1% FSO Typical.
Ambient Drift		<±0.01%/C FSO Typical.
Noise Immunity		125dB CMRR Average. (1.6kV Peak Limit.)
R.F. Immunity		<1% Effect FSO Typical.
Isolation Voltage		1.6kVac/dc Peak Input to Output for 60sec.
Response Time		200msec Typical. (10 to 90% 100msec Typical.)
Operating Temperature		0~70C.
Storage Temperature		-20~80C.
Operating Humidity		90%RH Max. Non-Condensing.
Construction		Socket Plug-In Type With Barrier Terminals.
Relative Humidity	-Input	0~100C for Input Range.
	(Function 29) -Range	0~100%RH Over 0~100C Input.
	-Accurate to	<±1% FSO Typical.

Note 1. Refer to *IN-HWD Humidity and Temperature Converter* for Wet and Dry Bulb installation guide.

Note 2. Specifications based on Standard Calibration Unit, unless otherwise specified.

Note 3. Due to ongoing research and development, designs, specifications, and documentation are subject to change without notification.

No liability will be accepted for errors, omissions or amendments to this specification.

Note 4. Further ranging and installation information supplied with each unit, and is available upon request.

Examples of Input Connection.

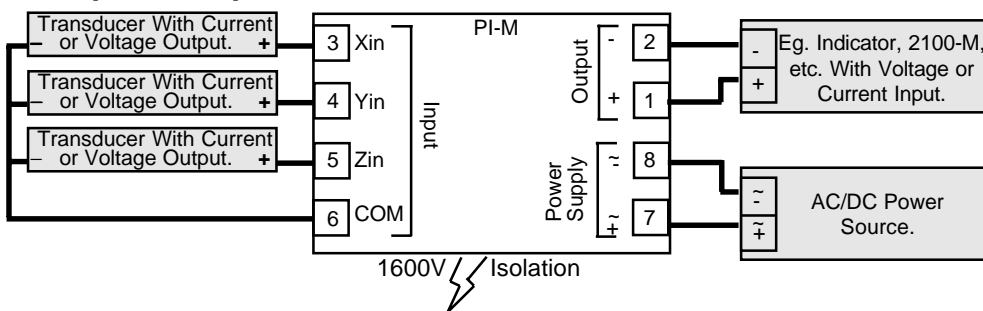

Terminations.

Output	1	+Ve
	2	-Ve
Input	3	Xin
	4	Yin
	5	Zin
	6	COM
P/S	7	~AC/+DC
	8	~AC/-DC

Dimensions and Mounting.

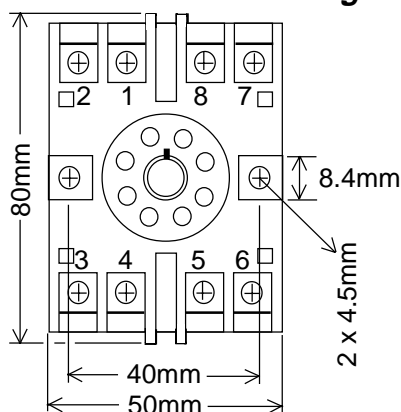

8PFA Octal Termination Base

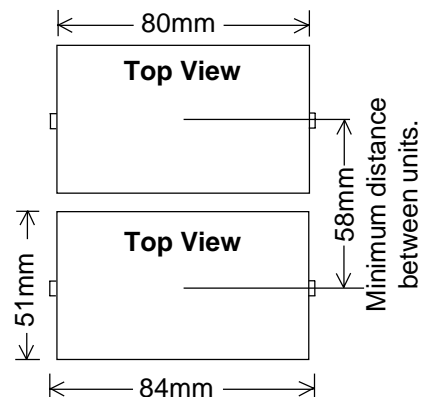
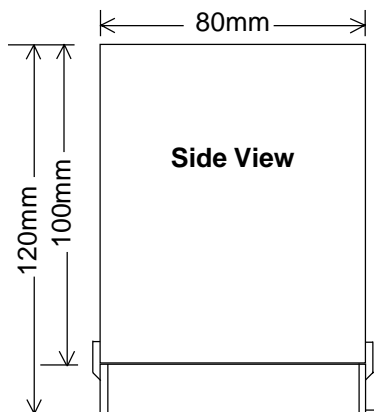

PI-K Programmable Isolating Resistance Transmitter.

Programmable Isolating 3 Wire Resistance Input to DC Current or DC Voltage Output Transmitter.

Features.

- Field Programmable Input and Output Ranges.
- Bi-Polar Output Ranges.
- Input to Output Isolation 1.6kV.
- High Accuracy 0.1%.
- Universal AC/DC Power Supply.
- Compact DIN Rail Mount Enclosure.
- Available Standard or Special Calibration.



Ordering Information.

PI-K-X Standard Calibration: Input 0~1k Ω ; Output 4~20mA; High Voltage Power Supply.

PI-K - - - - Special Range Special Range Calibration.
IR OR PS

Other PI- models include:
 PI-B Bridge / Strain gauge;
 PI-D DC;
 PI-F Frequency;
 PI-M Maths Computing;
 PI-N RTD Differential Pt100;
 PI-P Potentiometer;
 PI-R RTD Pt100;
 PI-S Dual Setpoint Controller;
 PI-T Thermocouple.

INPUT RANGES				OUTPUT RANGES			
Resistance (Ω)	IR	Resistance (Ω)	IR	Voltage	OR	Current	OR
0~10 Ω	1	0~4.7k Ω	19	0~500mV	A	0~1mA	1
0~20 Ω	2	0~5k Ω	20	0~1V	B	0~2mA	2
0~22 Ω	3	0~7.5k Ω	21	0~2V	C	0~5mA	3
0~25 Ω	4	0~10k Ω	22	0~3V	D	0~10mA	4
0~47 Ω	5	0~20k Ω	23	0~4V	E	0~16mA	5
0~50 Ω	6	10~50 Ω	24	0~5V	F	0~20mA	6
0~75 Ω	7	25~75 Ω	25	0~6V	G	1~5mA	7
0~100 Ω	8	50~100 Ω	26	0~8V	H	2~10mA	8
0~200 Ω	9	75~225 Ω	27	0~10V	I	4~20mA	9
0~220 Ω	10	150~250 Ω	28	0~12V	J	-1~1mA	10
0~250 Ω	11	250~500 Ω	29	1~5V	K	-2~2mA	11
0~470 Ω	12	500~1000 Ω	30	2~10V	L	-5~5mA	12
0~500 Ω	13	1~1.5k Ω	31	-1~1V	M	-10~10mA	13
0~750 Ω	14	2~4k Ω	32	-2~2V	N	-20~20mA	14
0~1k Ω	15	4~10k Ω	33	-5~5V	O		
0~2k Ω	16	5~15k Ω	34	-10~10V	P		
0~2.2k Ω	17	10~20k Ω	35	-12~12V	Q		
0~2.5k Ω	18	15~20k Ω	36				
Special Input Range			Z	Special Output Range			Z

POWER SUPPLY		PS
High Voltage Power Supply: 70~270Vac and 80~380Vdc		H
Mid Voltage Power Supply: 24~80Vac and 20~90Vdc		M
Low Voltage Power Supply: 8~30Vac and 8~30Vdc		L

Note: Power supply H is field selectable for M, and M for H. Power supply L must be ordered separately.

Ordering Examples.

- 1/ PI-K-8-1-L 0~100 Ω Input; 0~1mA Output; Low Voltage Power Supply.
 2/ PI-K-Z-P-H-0/3K 0~3k Ω Input; -10~10V Output; High Voltage Power Supply.

Quality Assurance Programme.

The modern technology and strict procedures of the ISO9001 Quality Assurance Programme applied during design, development, production and final inspection grant long term reliability of the instrument.

PI-K Specifications.

Resistance Input		3 Wire Resistance. Lead Wire Resistance = 10Ω/Wire Max. Field Programmable Zero From 5Ω to 20kΩ. Field Programmable Span From 10Ω to 20kΩ. Suitable for 2 Wire Connection. (Offset Calibration Needed.)
	- Excitation	0.8mA for Input < 2kΩ. 0.08mA for Input ≥ 2kΩ.
Output	- Voltage	Field Programmable From 500mVdc to ±12Vdc. Maximum Output Drive = 10mA.
	- Current	Field Programmable From 1mAdc to ±20mAdc. Maximum Output Drive = 10Vdc. (500Ω @ 20mA.)
Universal P/S	-Standard High (H)	70~270Vac and 80~380Vdc; 50/60Hz; 4VA.
	-Standard Mid (M)	24~80Vac and 20~90Vdc; 50/60Hz; 4VA.
	-Low Voltage (L)	8~30Vac and 8~30Vdc; 50/60Hz; 4VA.
	-Circuit Sensitivity	<±0.001%/V FSO Typical.
Accurate to		<±0.1% FSO Typical.
Linearity & Repeatability		<±0.1% FSO Typical.
Ambient Drift		<±0.01%/C FSO Typical.
Noise Immunity		125dB CMRR Average. (1.6kV Peak Limit.)
R.F. Immunity		<1% Effect FSO Typical.
Isolation Voltage		1.6kVac/dc Input to Output for 60sec.
Response Time		200msec Typical. (10 to 90% 50msec Typical.)
Operating Temperature		0~70C.
Storage Temperature		-20~80C.
Operating Humidity		90% RH Max. Non-Condensing.
Construction		Socket Plug-In Type With Barrier Terminals.

Note 1. Specifications based on Standard Calibration Unit, unless otherwise specified.

Note 2. Due to ongoing research and development, designs, specifications, and documentation are subject to change without notification.

No liability will be accepted for errors, omissions or amendments to this specification.

Note 3. Further ranging and installation information supplied with each unit, and is available upon request.

Examples of Input Connection.

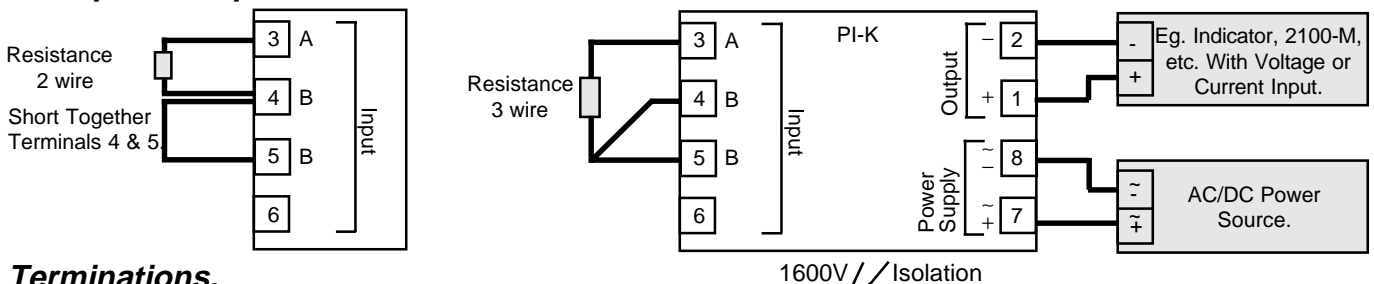

Terminations.

Output	1	+Ve	Input	3	A
	2	-Ve		4	B
P/S	7	~AC/+DC		5	B
	8	~AC/-DC		6	NOT USED

Dimensions and Mounting.

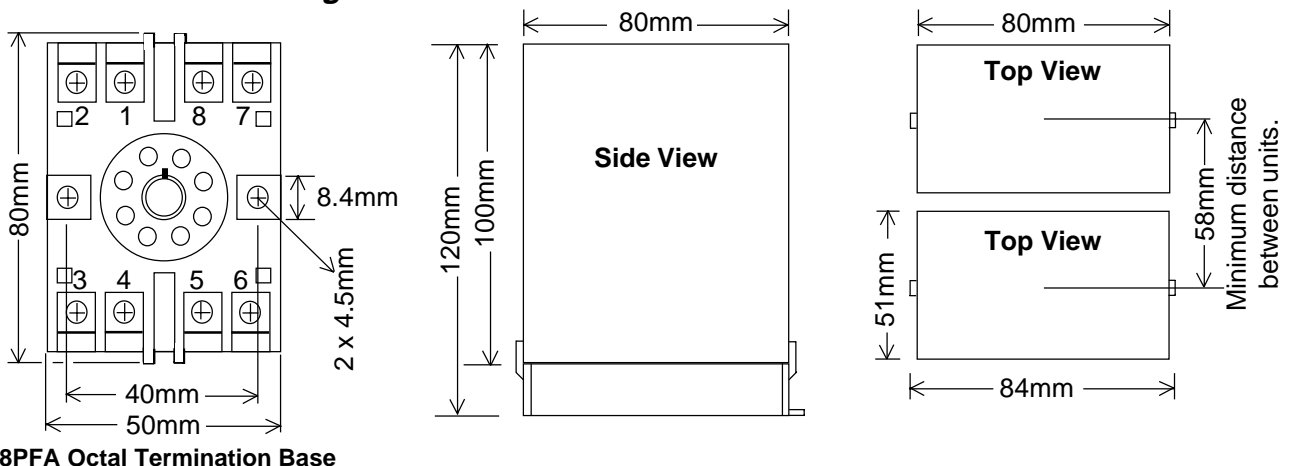

PI-F Programmable Isolating Frequency Transmitter.

Programmable, Isolating Frequency Input to DC Current or DC Voltage Output Transmitter.

Features.

- Field Programmable Input and Output Ranges.
- Bi-Polar Output Ranges.
- Fast Response Time, Allowing Accurate Control.
- Impedance Matching on Input.
- Contact Closure Selection.
- Crystal Locked Period Measurement.
- Input to Output Isolation 1.0kV.
- High Accuracy 0.1%.
- Universal AC/DC Power Supply.
- Compact DIN Rail Mount Enclosure.
- Available Standard or Special Calibration.



Other PI- models include:
 PI-B Bridge / Strain gauge;
 PI-D DC;
 PI-K Resistance;
 PI-M Maths Computing;
 PI-N RTD Differential Pt100;
 PI-P Potentiometer;
 PI-R RTD Pt100;
 PI-S Dual Setpoint Controller;
 PI-T Thermocouple.

Ordering Information.

PI-F-X Standard Calibration: Input 0~100Hz; Output 4~20mA;
 High Voltage Power Supply.

PI-F - - - - Special Range Special Range Calibration.
 IR OR PS

INPUT RANGES		OUTPUT RANGES			
Frequency	IR	Voltage	OR	Current	OR
0~0.4Hz	1	0~500mV	A	0~1mA	1
0~0.5Hz	2	0~1V	B	0~2mA	2
0~1Hz	3	0~2V	C	0~5mA	3
0~2Hz	4	0~3V	D	0~10mA	4
0~4Hz	5	0~4V	E	0~16mA	5
0~5Hz	6	0~5V	F	0~20mA	6
0~10Hz	7	0~6V	G	1~5mA	7
0~20Hz	8	0~8V	H	2~10mA	8
0~40Hz	9	0~10V	I	4~20mA	9
0~50Hz	10	0~12V	J	-1~1mA	10
0~100Hz	11	1~5V	K	-2~2mA	11
0~200Hz	12	2~10V	L	-5~5mA	12
0~400Hz	13	-1~1V	M	-10~10mA	13
0~500Hz	14	-2~2V	N	-20~20mA	14
0~1kHz	15	-5~5V	O		
0~2kHz	16	-10~10V	P		
0~4kHz	17	-12~12V	Q		
0~5kHz	18				
0~10kHz	19				
0~20kHz	20				
0~40kHz	21				
Special Input Range	Z	Special Output Range			Z

POWER SUPPLY	PS
High Voltage Power Supply: 70~270Vac and 80~380Vdc	H
Mid Voltage Power Supply: 24~80Vac and 20~90Vdc	M
Low Voltage Power Supply: 8~30Vac and 8~30Vdc	L

Note: Power supply H is field selectable for M, and M for H. Power supply L must be ordered separately.

Ordering Examples.

- 1/ PI-F-15-1-L 0~1kHz Input; 0~1mA Output; Low Voltage Power Supply.
- 2/ PI-F-Z-P-H-0/28Hz 0~28Hz Input; -10~10V Output; High Voltage Power Supply.

Quality Assurance Programme.

The modern technology and strict procedures of the ISO9001 Quality Assurance Programme applied during design, development, production and final inspection grant long term reliability of the instrument.

PI-F Specifications.

Frequency Input	2 Wire Sine / Square / Pulse, Uni-polar / Bi-polar. (Signals < 2Vpp Bipolar Only.) Minimum Input Signal = 15mVpp. Maximum Input Signal = 100Vpp. Field Programmable Span From 0.4Hz to 40kHz. (60Hz Max. for Contact Input.) Adjustable Input Impedance From 100Ω to 100kΩ. Open Collector Output, Limited to 12Vdc @ 10mA. Time-out to 0% after: 200÷(Frequency X Prescale) sec. Cut-off Frequency at 0.5% FSO.
- Transmitter P/S	12Vdc±5% Common to COM. (Terminal 4.) Max Load = 30mA.
Output - Voltage	Field Programmable From 500mVdc to ±12Vdc. Maximum Output Drive = 10mA.
- Current	Field Programmable From 1mAdc to ±20mAdc. Maximum Output Drive = 10Vdc. (500Ω @ 20mA.)
Universal P/S - Standard High (H)	70~270Vac and 80~380Vdc; 50/60Hz; 4VA.
- Standard Mid (M)	24~80Vac and 20~90Vdc; 50/60Hz; 4VA.
- Low Voltage (L)	8~30Vac and 8~30Vdc; 50/60Hz; 4VA.
- Circuit Sensitivity	<±0.001%/V FSO Typical.
Accurate to	<±0.1% FSO Typical.
Linearity & Repeatability	<±0.1% FSO Typical.
Ambient Drift	<±0.01%/C FSO Typical.
Noise Immunity	125dB CMRR Average. (1.0kV Peak Limit.)
R.F. Immunity	<1% Effect FSO Typical.
Isolation Voltage	1.0kVac/dc Input to Output for 60sec.
Response Time	(1/(FREQUENCY x PRESCALE)) + 0.2sec. Typical. (Except Time-out to 0%.)
Operating Temperature	0~70C.
Storage Temperature	-20~80C.
Operating Humidity	90%RH Max. Non-Condensing.
Construction	Socket Plug-In Type With Barrier Terminals.

Note 1. Specifications based on Standard Calibration Unit, unless otherwise specified.

Note 2. Due to ongoing research and development, designs, specifications, and documentation are subject to change without notification.

No liability will be accepted for errors, omissions or amendments to this specification.

Note 3. Further ranging and installation information supplied with each unit, and is available upon request.

Examples of Input Connection.

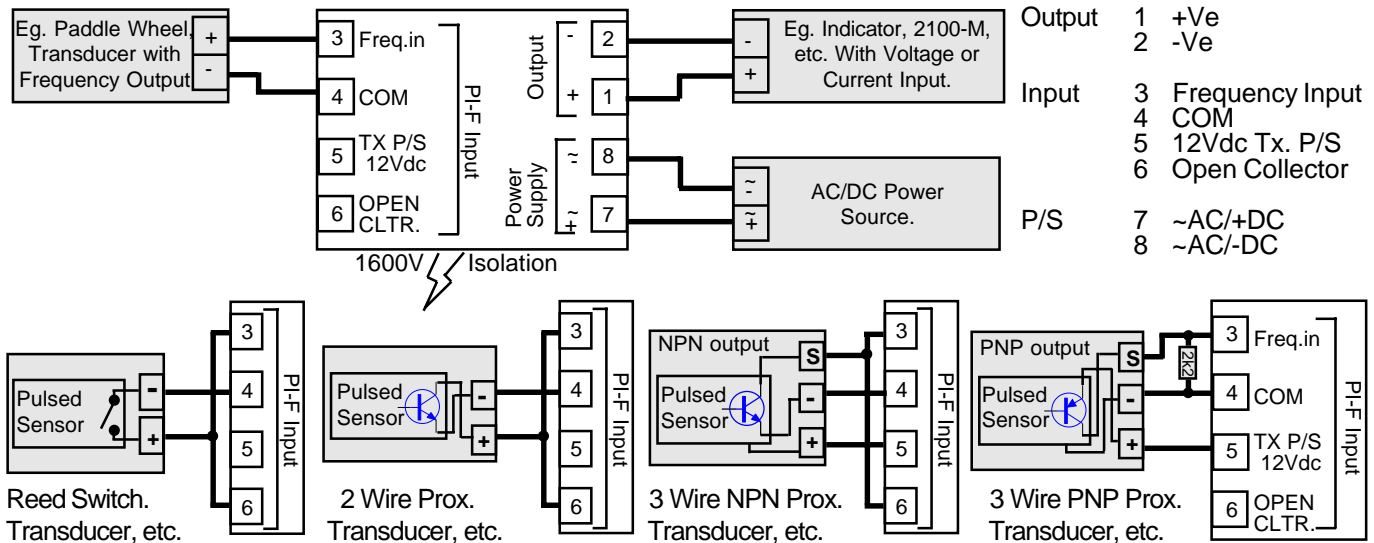

Terminations.

Output	1 +Ve
	2 -Ve
Input	3 Frequency Input
	4 COM
	5 12Vdc Tx. P/S
	6 Open Collector
P/S	7 ~AC/+DC
	8 ~AC/-DC

Dimensions and Mounting.

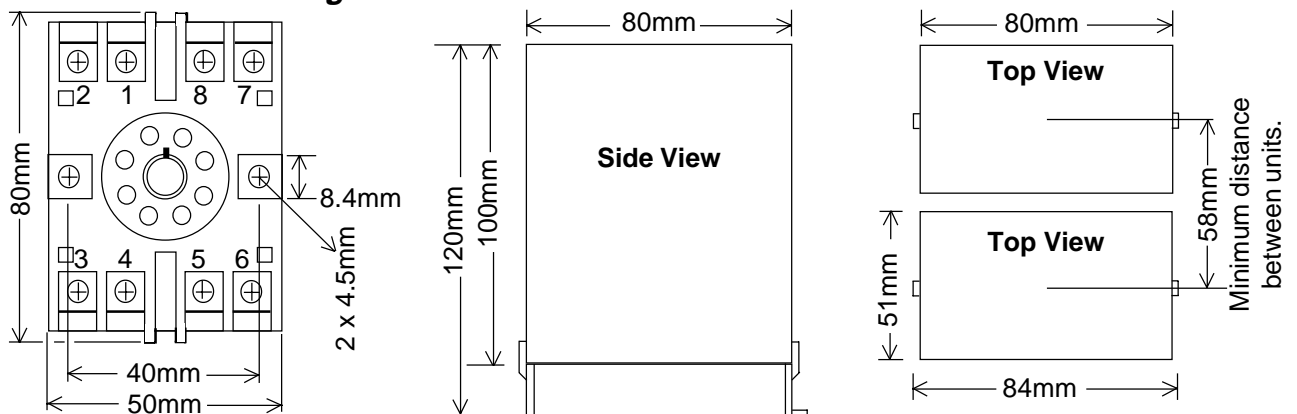

8PFA Octal Termination Base

PI-D Programmable Isolating DC Transmitter.

Programmable Isolating DC Voltage or DC Current Input to DC Current or DC Voltage Output Transmitter.

Features.

- Field Programmable Input and Output Ranges.
- Bi-Polar Input and Output Ranges.
- Input to Output Isolation 1.6kV.
- High Accuracy 0.1%.
- Universal AC/DC Power Supply.
- Transmitter Power Supply Standard.
- Compact DIN Rail Mount Enclosure.
- Available Standard or Special Calibration.



Other PI- models include:
 PI-B Bridge / Strain gauge;
 PI-F Frequency;
 PI-K Resistance;
 PI-M Maths Computing;
 PI-N RTD Differential Pt100;
 PI-P Potentiometer;
 PI-R RTD Pt100;
 PI-S Dual Setpoint Controller;
 PI-T Thermocouple.

Ordering Information.

PI-D-X Standard Calibration: Input 4~20mA; Output 4~20mA;
 High Voltage Power Supply.

PI-D - - - - Special Range Special Range Calibration.
 IR OR PS

INPUT RANGES				OUTPUT RANGES			
Voltage	IR	Current	IR	Voltage	OR	Current	OR
0~10mV	A	0~200µA	1	0~500mV	A	0~1mA	1
0~20mV	B	0~500µA	2	0~1V	B	0~2mA	2
0~50mV	C	0~1mA	3	0~2V	C	0~5mA	3
0~100mV	D	0~2mA	4	0~3V	D	0~10mA	4
0~200mV	E	0~5mA	5	0~4V	E	0~16mA	5
0~500mV	F	0~10mA	6	0~5V	F	0~20mA	6
0~1V	G	0~20mA	7	0~6V	G	1~5mA	7
0~2V	H	0~50mA	8	0~8V	H	2~10mA	8
0~4V	I	0~100mA	9	0~10V	I	4~20mA	9
0~5V	J	1~5mA	10	0~12V	J	-1~1mA	10
0~10V	K	2~10mA	11	1~5V	K	-2~2mA	11
0~20V	L	4~20mA	12	2~10V	L	-5~5mA	12
0~50V	M	10~50mA	13	-1~1V	M	-10~10mA	13
0~100V	N	-1~1mA	14	-2~2V	N	-20~20mA	14
0~150V	O	-10~10mA	15	-5~5V	O		
1~2V	P	-20~20mA	16	-10~10V	P		
1~5V	Q	20~4mA *	17	-12~12V	Q		
2~10V	R	50~10mA *	18				
-1~1V	S						
-5~5V	T						
-10~10V	U						
Special Input Range			Z	Special Output Range			Z

Ranges with '*' beside them must have the polarity of their connections reversed.

POWER SUPPLY	PS
High Voltage Power Supply: 70~270Vac and 80~380Vdc	H
Mid Voltage Power Supply: 24~80Vac and 20~90Vdc	M
Low Voltage Power Supply: 8~30Vac and 8~30Vdc	L

Note: Power supply H is field selectable for M, and M for H. Power supply L must be ordered separately.

Ordering Examples.

- 1/ PI-D-K-1-L 0~10V Input; 0~1mA Output; Low Voltage Power Supply.
- 2/ PI-D-Z-P-H-0/8V 0~8V Input; -10~10V Output; High Voltage Power Supply.

Quality Assurance Programme.

The modern technology and strict procedures of the ISO9001 Quality Assurance Programme applied during design, development, production and final inspection grant long term reliability of the instrument.

PI-D Specifications.

Input	-Voltage	Field Programmable From 10mV to 150Vdc and Bipolar. Minimum Input Resistance = 200kΩ.
	- Current	Maximum Over-range = 170Vdc Continuous. Field Programmable From 200μA to 100mAdc and Bipolar. Input Resistance = 25Ω.
	-Transmitter P/S	Maximum Over-range = 120mAdc Continuous. 20Vdc±5% Common to Input Com. (Terminal 4.) Max Load = 30mA. Ripple < 20mV Typical at 30mA Load.
Output	-Voltage	Field Programmable From 500mV to ±12Vdc. Maximum Output Drive = 10mA.
	-Current	Field Programmable From 1mA to ±20mAdc. Maximum Output Drive = 10Vdc. (500Ω @ 20mA.)
Universal P/S	-Standard High (H)	70~270Vac and 80~380Vdc; 50/60Hz; 4VA.
	-Standard Mid (M)	24~80Vac and 20~90Vdc; 50/60Hz; 4VA.
	-Low Voltage (L)	8~30Vac and 8~30Vdc; 50/60Hz; 4VA.
	-Circuit Sensitivity	<±0.001%/V FSO Typical.

Accurate to	<±0.1% FSO Typical.
Linearity & Repeatability	<±0.1% FSO Typical.
Ambient Drift	<±0.01%/C FSO Typical.
Noise Immunity	125dB CMRR Average. (1.6kVac Peak Limit.)
R.F. Immunity	<1% Effect FSO Typical.
Isolation Voltage	1.6kVac/dc Peak Input to Output for 60sec.
Response Time	200msec Typical. (From 10 to 90% 50msec Typical.)
Operating Temperature	0~70C.
Storage Temperature	-20~80C.
Operating Humidity	90%RH max. Non-Condensing.
Construction	Socket Plug-In Type with Barrier Terminals.

Note 1. Specifications based on Standard Calibration Unit, unless otherwise specified.

Note 2. Due to ongoing research and development, designs, specifications, and documentation are subject to change without notification.

No liability will be accepted for errors, omissions or amendments to this specification.

Note 3. Further ranging and installation information supplied with each unit, and is available upon request.

Examples of Input Connection.

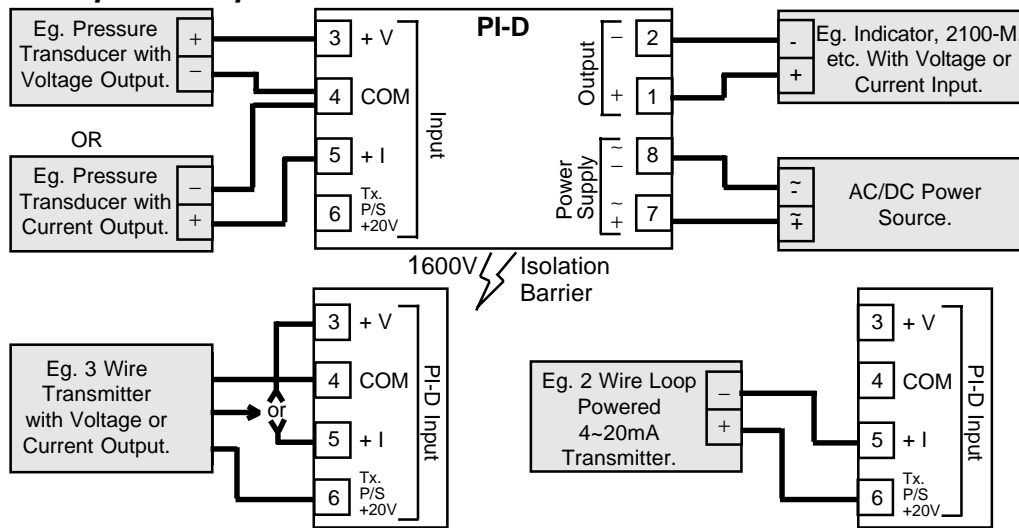

Terminations.

Output	1 +Ve
	2 -Ve
Input	3 +V
	4 COM
	5 +I
	6 Tx. P/S 20V
P/S	7 ~AC/+DC
	8 ~AC/-DC

Dimensions and Mounting.

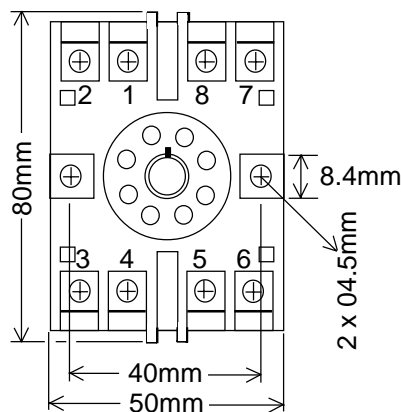

8PFA Octal Termination Base

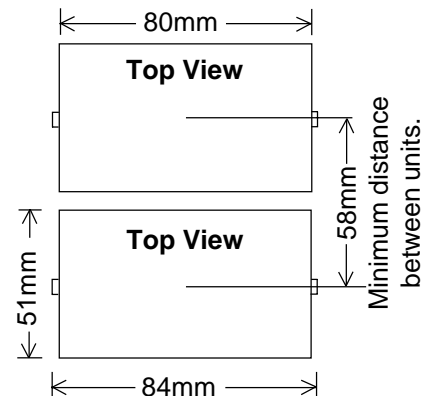
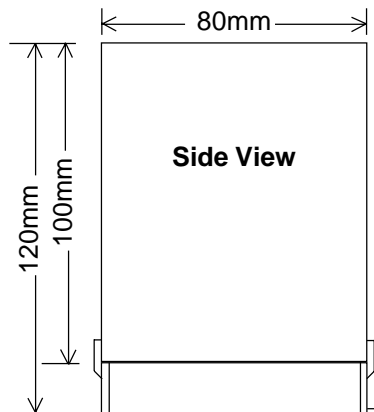

Intech INSTRUMENTS LTD.

Christchurch
Ph: 03 343 0646
Fx: 03 343 0649
2.02-2

Nelson
Ph: 03 546 6840
Fx: 03 548 8797

Auckland
Ph: 09 827 1930
Fx: 09 827 1931

pi-d_2pg.p65
ISSUE 200999

PI-T Specifications.

Input

Note 1: The input range must be within the specified **min / max range** of the thermocouple type.

Note 2: Each PI-T is only rangeable within the specified 'Thermocouple Type'.

Thermocouple Type			Field Programmable Input Ranges								Linearity and Accuracy:
Type	Specification Range (C)	Specification Range (F)	Zero Offset				Span (Max. In - Zero)				%, ±1C (±2F)
			Min.(C)	Max.(C)	Min.(F)	Max.(F)	Min.(C)	Max.(C)	Min.(F)	Max.(F)	
J	0~800	0~1500	0	600	0	1100	200	800	400	1500	0.25
K	0~1200	0~2200	0	1000	0	1800	200	1200	400	2200	0.25
N	0~1200	0~2200	0	1000	0	1800	200	1200	400	2200	0.25
R	400~1700	750~3100	0	1300	0	2400	400	1700	750	3100	0.5
S	400~1700	750~3100	0	1300	0	2400	400	1700	750	3100	0.5
T	-100~200	-150~400	-100	100	-150	200	100	300	200	550	0.5

- Impedances	1MΩ Min. Input Impedance. 100Ω Max. Thermocouple Lead Resistance.
Output	- Voltage Field Programmable From ±500mVdc to ±12Vdc. Maximum Output Drive = 10mA.
- Current	Field Programmable From ±1mAdc to ±20mAdc. Maximum Output Drive = 10Vdc. (500Ω @ 20mA.)
Universal P/S	-Standard High (H) 70~270Vac and 80~380Vdc; 50/60Hz; 4VA. -Standard Mid (M) 24~80Vac and 20~90Vdc; 50/60Hz; 4VA. -Low Voltage (L) 8~30Vac and 8~30Vdc; 50/60Hz; 4VA. -Circuit Sensitivity <±0.001%/V FSO Typical.
Cold Junction Compensation Accuracy.	<0.03C/C (0.06F/F) Typical.
Repeatability	<±0.1% FSO Typical.
Ambient Drift	<±0.01%/C FSO Typical.
Noise Immunity	125dB CMRR Average. (1.6kV Peak Limit.)
R.F. Immunity	<1% Effect FSO Typical.
Isolation Voltage	1.6kVac/dc Input to Output for 60sec.
Response Time	200msec Typical. (From 10 to 90% 50msec Typical.)
Operating Temperature	0~70C.
Storage Temperature	-20~80C.
Operating Humidity	90% Max. RH Non-Condensing.
Construction	Socket Plug-In Type With Barrier Terminals.

Note 1. Specifications based on Standard Calibration Unit, unless otherwise specified.

Note 2. Due to ongoing research and development, designs, specifications, and documentation are subject to change without notification.
No liability will be accepted for errors, omissions or amendments to this specification.

Note 3. Further ranging and installation information supplied with each unit, and is available upon request.

Examples of Input Connections.

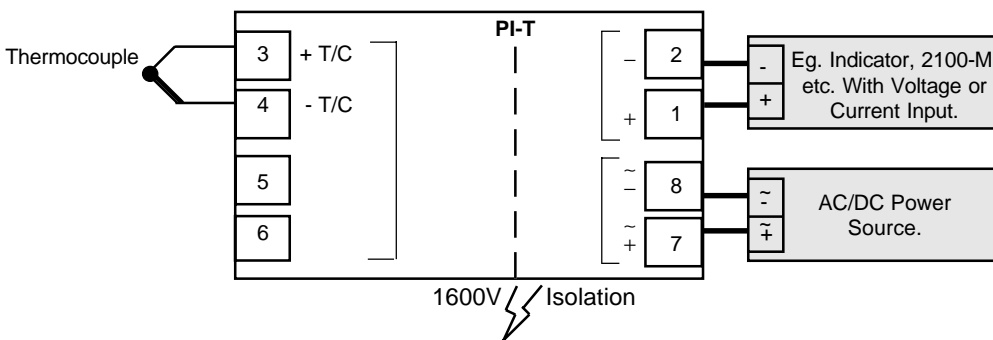

Terminations.

Output	1	+Ve
	2	-Ve
Input	3	+T/C
	4	-T/C
P/S	7	~AC / +DC
	8	~AC / -DC

Dimensions and Mounting.

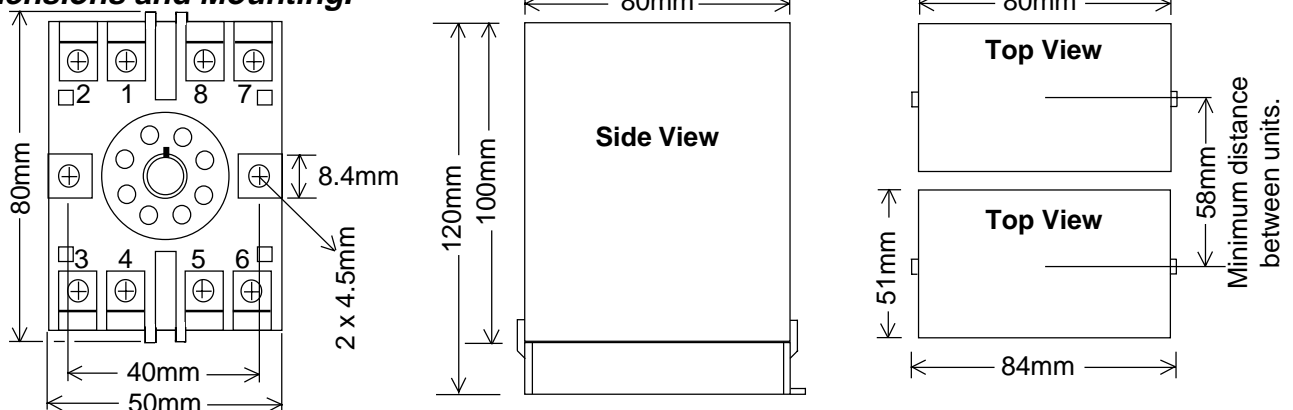

8PFA Octal Termination Base

Intech INSTRUMENTS LTD.

Christchurch
Ph: 03 343 0646
Fx: 03 343 0649
11.02-2

Nelson
Ph: 03 546 6840
Fx: 03 548 8797

Auckland
Ph: 09 827 1930
Fx: 09 827 1931