

# General Specifications

## SR1000 Recorder

LF 4D8B1-42U

The SR1000 is a small compact recorder using a 100mm (4 inch) wide paper. The family consists of 1,2,3 pen and a 6 dot model. Its input is universal, which means that it is freely programmable direct voltage/current, Thermo-couple, Resistance Temperature Detector, digital input, etc. In addition to analog recording, digital data like date & time, measured values, units, scale values, chart speed, alarms, etc. can also be printed. High reliability is realized by YOKOGAWA's contact free technology, such as high breakdown voltage semiconductor relays, and DC brushless servomotors. Furthermore the SR has a short case of only 220mm. The SR can be used as a monitoring device and as a quality control instrument in many industrial automation applications.



SR1000 6 dot-model

### STANDARD SPECIFICATIONS

#### General Specifications

#### Construction

##### Mounting:

Flush Panel Mounting (vertical), mounting next to each other (horizontal and vertical).

Mounting may be inclined up to 30°, rear below front (with horizontal base).

##### Allowable panel thickness:

2 to 26mm (0.78 to 1.02 inch)

##### Material:

Case: drawn steel, front door: aluminium die casting.

##### Finish:

Case and door-frame: lamp black (Mansell 0.8Y2.5/0.4 or equivalent)

##### Door:

Splash and dust-proof (based on DIN 40050-IP54).

##### Dimensions:

144X144X220mm (see dimensional drawings)

##### Weight (approx.):

1 pen	3.1kg (6.8lbs)
2 pen	3.3kg (7.3lbs)
3 pen	3.5kg (7.7lbs)
6 dot	3.4kg (7.5lbs)

#### Model

1, 2, and 3 pen, 6 dot-model.

#### Input

##### Inputs:

DCV: Direct Current Voltage input 20mV to 20V range.

TC: Thermo couple.

RTD: Resistance Temperature Detector.

DI: Digital Input (contact or DC Voltage, TTL level).

DCA: Direct Current Input (using external shunt resistor (10Ω, 100Ω, 250Ω) )

Measuring range: selectable per channel

Input Type	Range	Measuring Range
DC V	20mV	-20.00 to 20.00mV
	60mV	-60.00 to 60.00mV
	200mV	-200.0 to 200.0mV
	2V	-2.000 to 2.000V
	6V	-6.000 to 6.000V
	20V	-20.00 to 20.00V

T01.EPS

#### Note:

SR1000 recorder is a product of Yokogawa Electric corporation.  
SR1000 recorder is sold in North America and European countries only.

Input Type	Range	Measuring Range °C	Measuring Range °F
TC	R <sup>*1</sup>	0.0 to 1760.0°C	32 to 3200°F
	S <sup>*1</sup>	0.0 to 1760.0°C	32 to 3200°F
	B <sup>*1</sup>	0.0 to 1820.0°C	32 to 3308°F
	K <sup>*1</sup>	-200.0 to 1370.0°C	-328 to 2498°F
	E <sup>*1</sup>	-200.0 to 800.0°C	-328.0 to 1472.0°F
	J <sup>*1</sup>	-200.0 to 1100.0°C	-328.0 to 2012.0°F
	T <sup>*1</sup>	-200.0 to 400.0°C	-328.0 to 752.0°F
	N <sup>*1</sup>	0.0 to 1300.0°C	32 to 2372°F
	W <sup>*2</sup>	0.0 to 2315.0°C	32 to 4199°F
	L <sup>*3</sup>	-200.0 to 900.0°C	-328.0 to 1652.0°F
U <sup>*3</sup>	-200.0 to 400.0°C	-328.0 to 752.0°F	

Input Type	Range	Measuring Range °C	Measuring Range °F
RTD	Pt100 <sup>*4</sup>	-200.0 to 600.0°C	-328.0 to 1112.0°F
	JPt100 <sup>*4</sup>	-200.0 to 550.0°C	-328.0 to 1022.0°F

Input Type	Range	Measuring Range
DI (Digital Input)	Voltage Input	Less than 2.4V : OFF ; More than 2.4V : ON (TTL)
	Contact Input	Contact ON / OFF

T02.EPS

- \*1 R, S, B, K, E, J, T, N: IEC 584-1 (1995), JIS C 1602-1995
- \*2 W: W-5%Re/W-26%Re (Hoskins Mfg. Co.)
- \*3 L: Fe-CuNi, DIN 43710, U: Cu-CuNi, DIN 43710
- \*4 Pt100: IEC 751-1995, JPt100: JIS C 1604-1989

**Measurement Interval:**

Pen model: 125ms/channel.  
Dot printing model: 5sec/6channel

**A/D Integration Time:**

20ms(50Hz) or 16.7ms (60Hz), automatically selected depending on the power supply frequency for pen model only.  
100ms integration time for dot printing model only

**TC Burnout:**

ON/OFF selectable (per channel).  
Burnout upscale/downscale selectable (common for all channels)  
Normal: less than 2kΩ, burnout: more than 10MΩ.  
Measuring current: approx. 100nA.

**Filter:**

Pen model:  
Signal damping (ON/OFF selectable per channel; in case of ON: time constant 2, 5, 10sec).  
Dot printing model:  
Moving average (ON/OFF selectable per channel; in case of ON: averaging times from 2 to 16 scans)

**Calculation:**

Interchannel difference:  
Between any two channels, however reference channel number must be less than measuring channel number.  
Available for DCV, TC, and RTD range.  
Both channels must have same range.

**Linear scaling:**

Available for DCV range.  
Scaling limits: -19999 to 20000  
Data display & printout range: -19999 to 20000  
Decimal point: user selectable (should be specified when entering scale value)  
Unit: user settable, up to 6 characters (alphanumerical & special characters).

**Square root:**

Available for DCV range.  
Scaling limits: -19999 to 20000  
Data display & printout range: -19999 to 20000  
Decimal point: user selectable  
Unit: user settable, up to 6 characters (alphanumerical & special characters).

**Offset function:**

Ranges: DCV, TC, RTD, SCL  
Compensation range: within 10% of recording span

**Recording and Printing**

**Recording Method:**

Pen model: Disposable felt pens, Plotter pen  
Dot printing model: 6 color wire dot.

**Pen Offset Compensation:**

ON/OFF selectable (Pen model only)

**Effective Recording Width: 100mm**

**Chart:**

Plain-paper Z-fold chart (16m)

**Step Response Time (pen):**

Less than 1sec (acc. to IEC TC85 method).

**Recording Period:**

Pen model:  
Continuous for each channel.  
Dot printing model:  
Max. 20sec/6channel, AUTO/FIX selectable  
AUTO: Analog recording interval is depending on the chart speed  
FIX: Analog recording interval is set to shortest period

**Chart speed:**

User can select the chart speed by front panel key as shown below.

Pen model (40 speeds): (mm/h)

10	15	20	25	30	40	50
60	75	80	90	100	120	150
160	180	200	240	300	360	375
450	600	720	750	900	1200	1500
1800	2400	3000	3600	4500	4800	5400
6000	7200	9000	10800	12000		

T03.EPS

Dot printing model (28 speeds): (mm/h)

10	15	20	25	30	40	50
60	75	80	90	100	120	150
160	180	200	240	300	360	375
450	600	720	750	900	1200	1500

T04.EPS

**Chart Speed Change:**

speed 1, speed 2 change by remote control signals (option).

**Chart Speed Accuracy:**

within ±0.1% (for recordings longer than 1000mm, related to the grid of the chart paper)

**Relation between Chart Speed and Printout:**

Pen model:

Chart Speed	Periodic Printout	Alarm Printout
10 to 1500mm / h	Printout	Printout
1800 to 12000mm / h	No Printout	No printout

T05.EPS

Dot printing model:

Chart Speed	Channel No.	Periodic Printout	Alarm Printout
10 to 100mm / h	Printout	Printout	Printout
120 to 1500mm / h	No Printout	No printout	No printout

T06.EPS

**Relation between chart speed and printing intervals of periodic printouts:**

Pen model:

Chart Speed	Printing Interval of Periodic Printout
10, 15mm / h	Every 8 hours
20, 25, 30mm / h	Every 4 hours
40, 50, 60mm / h	Every 2 hours
75, 80, 90, 100, 120mm / h	Every hour
150, 160, 180mm / h	Every 30 minutes
200, 240, 300mm / h	Every 20 minutes
360 to 1500mm / h	Every 10 minutes
1800 to 12000mm / h	No printout

T07.EPS

Dot printing model:

Chart Speed	Printing Interval of Periodic Printout
10, 15mm / h	Every 8 hours
20, 25, 30mm / h	Every 4 hours
40, 50, 60, 75mm / h	Every 2 hours
80, 90, 100mm / h	Every hour
120 to 1500mm / h	No printout

T08.EPS

**Recording Colors:**

Pen model:

pen1=red, pen2=green, pen3=blue,  
plotter pen=purple

Dot printing model:

ch1=purple, ch2=red, ch3=green, ch4=blue,  
ch5=brown, ch6=black  
(color can be assigned to any channel)

**Recording Format:**

1. Analog recording:

Zone recording:

Span: More than 5mm (in 1mm steps).

Partial expanded recording:

Boundary position: 1 to 99%

Boundary value: Within recording span

2. Digital printout:

Channel (dot model only):

Channel number will be printed during analog recording. Approx. every 25mm this print will occur.

Alarm:

At the right side of the chart, ON/OFF mark CH. No., Type of alarm, ON/OFF time (h/m) will be printed. It is selectable to get ON/OFF time of alarms, or ON time, or no alarms (common for all channels).

Periodic printout:

At the left side of the chart, date(y/m/d), time(h/m), chart speed, scale value, and measured data of every channel will be printed.

It is selectable to get ON1 (printout all)/ON2 (printout date, time, chart speed)/OFF (no printout).

Message printout:

Using remote control option. Up to 5 messages.

Contents: time (h/m) and message (up to 16 characters).

Chart speed change printout:

Printouts of the chart speed and time when the change occurs, can be made by the user.

Manual printout:

Using panel key or remote control option. Measured values of that moment will be printed, while trend recording will be interrupted.

List printout:

Listings of range and alarm setting, etc. will be printed.

SET UP list printout:

Listing of settings in SET UP mode will be printed.

**Display**

**Display Method:**

LED (7 segments, 2 + 5 characters).

**Digital Display:**

AUTO: Channel No., kind of alarm, measured values, for each channel alternately

MAN: Channel No., kind of alarm, measured values, for one specific channel

DATE: Year/month/day will be displayed

TIME: Hour/min will be displayed

OFF: No display

**Other Displays:**

RCD: Recording in progress

ALM: Shared alarm (not corresponding to any channel)

**Power Supply**

**Rated Power Voltage:**

100 to 240VAC, automatically selected depending on the power supply voltage

**Usable power voltage ranges:**

90 to 132, 180 to 250VAC

**Rated Power Frequency:**

50/60 Hz, automatically selected

**Power Consumption: (approx.)**

	100V AC Power Source	240V AC Power Source	Maximum
3 pen	26VA*	36VA*	70VA
6 dot	25VA*	30VA*	50VA

T09.EPS

\* : for stable input

**Alarm**

**Number of levels:**

Up to four levels for every channel (High, Low, Delta high, Delta low).

**Display:**

Alarm status (ALM) will be displayed.

**Hysteresis:**

Approx. 0.5% of recording span (only high, low alarm) and 0%, selectable (common for all channels and all levels).

**Other Specifications**

**Clock:**

With Calendar function

**Clock Accuracy:**

±100 ppm, however not including error due to turning ON/OFF power

**Panel Key-lock:**

Can be set for RCD, PRINT, FEED key

**Setting Data protection:**

Requires a password

**Memory backup:**

Lithium battery to protect setting parameters.  
Life is approx. ten years (at room temperature, power off, and for standard model) and is installed inside the recorder.

**Insulation Resistance:**

Each terminal to ground terminal: more than 20MΩ (measured at 500VDC).

**Dielectric Strength:**

Power supply to ground terminal:  
1500V AC (50/60Hz), 1 min  
Contact output terminal to ground:  
1500V AC (50/60Hz), 1 min  
Measuring input terminal to ground:  
1000V AC (50/60Hz), 1 min  
Between measuring input terminals:  
1000V AC (50/60Hz), 1 min  
(except for RTD, since b-terminal is common).  
Between remote control terminal to ground:  
500V DC, 1min.

**Machine noise:**

Machine Noise Information Ordinance 3. GSGV, Jan. 18, 1991:  
The maximum sound pressure level is equal or less than 60dB (A) according to ISO7779.

**Safety Standards**

Certified by CSA22.2 No.1010.1  
Complies with EN61010-1

**EMC Standards**

Complies with EN55011 Group 1 Class A  
Complies with EN50082-2

**Normal Operating Conditions**

**Power voltage:** 90 to 132, 180 to 250VAC

**Power frequency:** 50Hz ±2%, 60Hz ±2%

**Ambient temperature:** 0 to 50 C

**Ambient humidity:** 20 to 80% RH (at 5 to 40°C)

**Vibration:** 10 to 60Hz, less than 0.2m/s<sup>2</sup>

**Shock:** not permissible

**Magnetic field:**

less than 400AT/m (DC and 50, 60Hz)

**Noise:**

Normal Mode (50/60Hz)

DCV: Peak value including signal must be less than 1.2 times the measuring range.

TC: Peak value including signal must be less than 1.2 times the measuring thermal electromotive force.

RTD: less than 50mV.

Common Mode (50/60Hz)

less than 250VAC rms. for the whole range

Maximum Differential Noise between Channels (50/60Hz)

Less than 250VAC rms

**Operating Position:**

Frontwards: 0° Backwards: within 30° from horizontal

**Warm-up Time:**

Min 30 minutes after power has been turned ON.

**Standard Performance**

**Measuring and Recording Accuracy:**

(following specifications apply to operation of the recorder under standard operation conditions: temperature 23±2°C, humidity 55±10%RH, power supply voltage 90 to 132V, 180 to 250V AC, power supply frequency 50/60Hz ±1%, warmup time at least 30 minutes, other ambient conditions like vibration should not adversely affect the recording operation).

Input	Range	Measuring (digital display)		Recording (analog)	
		Measurement Accuracy	Max. Resolution	Recording Accuracy	Resolution
DC V	20mV	±(0.2% of rdg+3 digits)	10µV	Measurement accuracy ±(0.3% of recording span)	Pen model dead band: 0.2% of recording span  Dot printing model resolution: 0.1mm
	60mV	±(0.2% of rdg+2 digits)	10µV		
	200mV	±(0.2% of rdg+2 digits)	100µV		
	2V	±(0.1% of rdg+2 digits)	1mV		
	6V	±(0.3% of rdg+3 digits)	1mV		
	20V	±(0.3% of rdg+2 digits)	10mV		
TC (Does not include reference junction compensation accuracy)	R S B	±(0.15% of rdg+1°C) but R, S: 0 to 100°C, ±3.7°C 100 to 300°C, ±1.5°C B: 400 to 600°C, ±2°C Accuracy less than 400°C is not specified	0.1°C	Measurement accuracy ±(0.3% of recording span)	Pen model dead band: 0.2% of recording span  Dot printing model resolution: 0.1mm
	K	±(0.15% of rdg+0.7°C) but -200 to -100°C ±(0.15% of rdg+1°C)			
	E	±(0.15% of rdg+0.5°C)			
	J T	±(0.15% of rdg+0.5°C) but J: -200 to -100°C ±(0.15% of rdg+0.7°C)	0.1°C		
	N	±(0.15% of rdg+0.7°C)			
	W	±(0.15% of rdg+1°C)	0.1°C		
	L U	±(0.15% of rdg+0.5°C) but L: -200 to -100°C ±(0.15% of rdg+0.7°C)	0.1°C		
	RTD	Pt100 JPt100	±(0.15% of rdg+0.3°C)		

T10.EPS

NOTE: Recording span is 100mm

Accuracy in case of scaling :

accuracy during scaling (digits)=

measuring accuracy (digits)×multiplier+2 digits (rounded up)

Where the multiplier=scaling span digits/recording span digits

Example :

DCV 6V range

recording span : 1.000 to 5.000 V

scaling span : 0.000 to 2.000

measuring accuracy= ±(0.3%×5V+2 digits)  
±(0.015V (15 digits)+2)  
±(17 digits)

multiplier= 2000 digits (0.000 to 2.000)/4000 digits  
(1.000 to 5.000V)= 0.5

Accuracy during scaling= 17 digits×0.5+2=11 digits  
(rounded up)

**Maximum Allowable Input Voltage:**

Less than 2VDC ranges and TC ranges:  $\pm 10$ VDC (cont.)  
6V to 20VDC:  $\pm 30$ VDC (cont.)

**Reference Junction Compensation Accuracy (above 0°C) :**

Type R, S, B, W:  $\pm 1^\circ\text{C}$

Type K, J, E, T, N, L, U:  $\pm 0.5^\circ\text{C}$

**Input Resistance:**

More than  $10\text{M}\Omega$  (TC, 20mV, 60mV, 200mV, 2V range)  
Approx.  $1\text{M}\Omega$  (6, 20V range).

**Input Source Resistance:**

DCV, TC input: less than  $2\text{k}\Omega$

RTD input: less than  $10\Omega/\text{wire}$  (Resistance is equal on all 3 wires)

**Input Bias Current:**

less than 10nA (however, when burnout is specified for TC: 100nA).

**Maximum Common Mode Voltage:**

250VAC rms (50/60Hz)

**Maximum Differential Noise between Channels**

250VAC rms (50/60Hz)

**Interference between Channels :**

120dB (500 $\Omega$ , the deviation in the case that 30V is applied to another channel)

**Common Mode Rejection Ratio:**

120dB (50/60Hz  $\pm 0.1\%$ , 500 $\Omega$  imbalance between  $\ominus$  terminal and ground)

**Normal Mode Rejection Ratio:**

40dB (50/60Hz  $\pm 0.1\%$ )

**Effect of Operating Conditions****Effect of Ambient Temperature:**

Effect of ambient temperature variation of  $10^\circ\text{C}$ .

Digital display: within  $\pm(0.1\%$  of rdg+1 digit)

Recording: within Digital display  $\pm 0.2\%$  of recording span (excluding RJC error)

**Effect of Power Supply:**

Effect of variation within 90 to 132V or 180 to 250VAC in rated power supply voltage:  
(50 or 60Hz is reference)

Digital display: within  $\pm 1$  digit

Recording: within  $\pm 0.1\%$  of recording span

Effect of rated power frequency variation of  $\pm 2\text{Hz}$  (100VAC is reference):

Digital display: within  $\pm(0.1\%$  of rdg+1 digit)

Recording: same as digital display

**Effect of Magnetic Field:**

Effect of AC (50/60Hz) or DC 400AT/m field:

Digital display: within  $\pm(0.1\%$  of rdg+10 digits)

Recording: less than  $\pm 0.5\%$  of recording span

**Effect of radio-frequency Electromagnetic Field:**

Effect of 27-500MHz 10V/m field

Digital display: within  $\pm(5\%$  of range +1 digit)

Recording: within  $\pm(5\%$  of range)

**Effect of Input Source Resistance:**

Effect of Input Source Resistance variation of  $+1\text{k}\Omega$ :

DCV range:

Ranges less than 2V: within  $\pm 10\mu\text{V}$

Ranges more than 6V: within  $-0.1\%$  of rdg

TC range:

within  $\pm 10\mu\text{V}$  (However  $\pm 100\mu\text{V}$  when TC burnout protection is set)

**RTD range:**

i) Effect of  $10\Omega$  per wire (resistances of three wire must be equal):

Digital display: within  $\pm(0.1\%$  of rdg+1 digit)

Recording: within Digital display  $\pm 0.1\%$  of recording span

ii) Effect of difference of three wires:

Digital display:  $0.1^\circ\text{C}$  per  $40\text{m}\Omega$  (approx.)

**Effect of Operating Position:**

Digital display: within  $\pm(0.1\%$  of rdg+1 digit) (within  $30^\circ$  backwards)

Recording: within Digital display  $\pm 0.1\%$  of recording span (within  $30^\circ$  backwards)

**Vibration:**

Effect when sine-wave motion of frequency 10 to 60Hz and acceleration of  $0.2\text{m/s}^2$  is applied to the instrument in the direction of three axes for two hours:

Digital display: within  $\pm(0.1\%$  of rdg+1 digit)

Recording: within Digital display  $\pm 0.1\%$  of recording span

**Transport and Storage Conditions**

No malfunction will occur under these conditions, however when returning to normal operation conditions, calibration might be necessary.

**Temperature:**  $-25^\circ\text{C}$  to  $60^\circ\text{C}$

**Humidity:** 5 to 95% RH (no condensation)

**Vibration:** 10 to 60Hz  $4.9\text{m/s}^2$

**Shock:** less than  $392\text{m/s}^2$  (inside packing)

## SPECIFICATIONS OF OPTIONAL FUNCTIONS

### / A1: Alarm Output Relay (2 contacts)

### / A2: Alarm Output Relay (4 contacts)

### / A3: Alarm Output Relay (6 contacts)

When alarm occurs, output relay on rear terminal will be activated.

1. Energize/non-energize selectable (common for all relays).
2. Relay contact rating: DC 250V/0.1A  
AC 250V/3A
3. Type of relay output: NO-C-NC

### / C3: RS-422A Communication Interface

By using this communication function, setting and control of data can be done by a host-computer.

Data can also be output to the host-computer.

1. Synchronizing format: start-stop asynchronous transmission
2. Specifications: conform to EIA RS-422A standard
3. Communication system: 4-wire half-duplex multi-drop connection (1: N (N=1 to 16))
4. Communication rate: 75, 150, 300, 600, 1200, 2400, 4800, 9600bps
5. Data length: 7 or 8 bit
6. Stop bit: 1 or 2 bit
7. Parity: Odd, even or none
8. Communication distance: Up to 500m
9. Communication mode: ASCII (control/setting/measured data) or Binary (measured data)

### /N1: Cu10, Cu25, Pt50 RTD input

Cu10, Cu25 and Pt50 RTD input become available.

Cu10, Cu25 Measurement Range

Input Type		Measurement Range
RTD	Cu10 (GE): $\alpha = 0.003855$ at 25°C Cu10 (L&N): $\alpha = 0.003852$ at 25°C Cu10 (WEED): $\alpha = 0.003862$ at 25°C Cu10 (BAILEY): Non-Linear Cu10: $\alpha = 0.00392$ at 20°C Cu10: $\alpha = 0.00393$ at 20°C Cu25: $\alpha = 0.00425$ at 0°C	-200 to 300°C (-328 to 572°F)
	Pt50	-200 to 600°C (-328 to 1112°F)

T11.EPS

### Measurement / Recording Accuracy

Input Type	Measurement Accuracy	Recording Accuracy
Cu10 (GE): $\alpha = 0.003855$ at 25°C Cu10 (L&N): $\alpha = 0.003852$ at 25°C Cu10 (WEED): $\alpha = 0.003862$ at 25°C Cu10 (BAILEY): Non-Linear Cu10: $\alpha = 0.00392$ at 20°C Cu10: $\alpha = 0.00393$ at 2°C	$\pm(0.4\%$ of rdg+1.0°C)	Measurement Accuracy $\pm(0.3\%$ of Recording span)
Cu25: $\alpha = 0.00425$ at 0°C	$\pm(0.3\%$ of rdg+0.8°C)	
Pt50	$\pm(0.3\%$ of rdg+0.6°C)	

T12.EPS

Note: If this option is specified, Measurement Accuracy of Pt100 and Jpt100 become  $\pm(0.3\%$  of rdg+0.4°C)

### /N3: PR20-40, Platinel TC input

PR20-40 and Platinel TC input become available.

PR20-40, Platinel Measurement Range

Input Type		Measurement Range
TC	PR20-40	0 to 1900°C (32 to 3452°F)
	Platinel	0 to 1400°C (32 to 2552°F)

T13.EPS

### Measurement / Recording Accuracy

Input Type	Measurement Accuracy	Recording Accuracy
PR20-40 0 to 450°C 450 to 750°C 750 to 1100°C 1100 to 1900°C	Not specified $\pm(0.9\%$ of rdg+3.2°C) $\pm(0.9\%$ of rdg+1.3°C) $\pm(0.9\%$ of rdg+0.4°C)	Measurement Accuracy $\pm(0.3\%$ of Recording span)
Platinel	$\pm(0.25\%$ of rdg+2.3°C)	

T14.EPS

### /D2: Temperature Unit Change

Using '°F' as temperature unit.

### /R1: Remote Control

5 are selectable from the below mentioned remote controls.

	Number of settings	Signal
Recording start/stop	1	level
Chart speed change	1	level
Message printout start*1	5	trigger
Manual printout start	1	trigger

\*1: Up to 5 messages can be set

**MODEL AND SUFFIX CODES**

Model	Suffix Codes		Description
SR1001	-A		SR1000 1-pen Recorder
SR1002	-A		SR1000 2-pen Recorder
SR1003	-A		SR1000 3-pen Recorder
SR1006	-A		SR1000 6-dot Recorder
Input Types		-0	Universal input
Optional Features		/ <input type="checkbox"/>	Refer to option code

Note 1: -A, -0 must be specified

Note 2: /A1, /A2 and /A3 select only one

T15.EPS

**STANDARD ACCESSORIES**

Name	1 pen	2 pen	3 pen	6 dot
Z-fold chart	1	1	1	1
6 color ribbon cassette	-	-	-	1
Disposable felt-pen cartridge	Red	1	1	-
	Green	-	1	-
	Blue	-	-	1
Plotter pen	Purple	1	1	-
Mounting brackets	2	2	2	2
Fuse (250V 500mA Timelag)	1	1	1	1
Instruction Manual	1	1	1	1

T16.EPS

**SPARES**

Name	Parts No.	Order Q'ty (units)	Description	
Z-fold chart	B9565AW	10	1 chart / unit	
6 color ribbon cassette	B9901AX	1	1 piece / unit	
Disposable felt-pen cartridge	Red	B9902AM	1	3 pieces / unit
	Green	B9902AN	1	3 pieces / unit
	Blue	B9902AP	1	3 pieces / unit
Plotter pen	Purple	B9902AR	1	3 pieces / unit
Mounting brackets	B9900BX	2	1 piece / unit	
Fuse (250V 800mA Timelag)	A1512EF	1	4 pieces / unit	
Lubricating oil (for dot printing model)	B9901AZ	1	1 piece / unit	

T17.EPS

**OPTION CODES**

Option Code	Description
/ A1	Alarm output relay (2 contacts)
/ A2	Alarm output relay (4 contacts)
/ A3	Alarm output relay (6 contacts)
/ C3	RS-422A Interface
/ D2	Temperature unit change
/ N1	Cu10, Cu25, Pt50 RTD input
/ N3	PR20-40, Platinel TC input
/ R1	Remote controls (5 plugs)

T18.EPS

**OPTIONAL ACCESSORIES**

Name	Model Code	Specification
Shunt resistor	4159 20	250Ω ±0.1%
	4159 21	100Ω ±0.1%
	4159 22	10Ω ±0.1%

T19.EPS

**REAR TERMINAL ARRANGEMENTS**

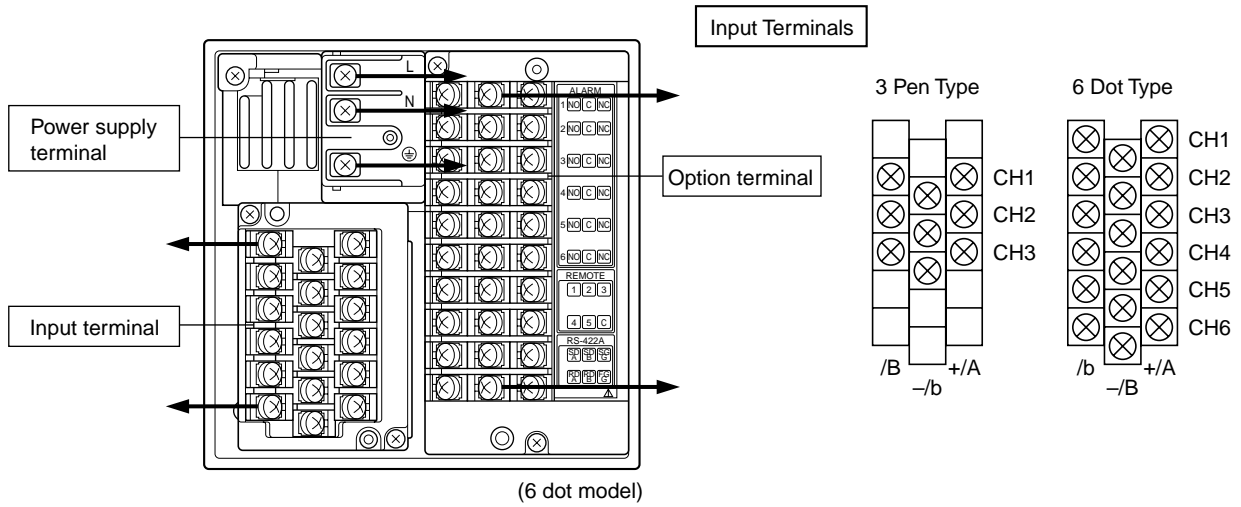

Note: The arrows show the direction in which the wires will be running when connected to the terminal.

**Option Terminals**

/A3/C3/R1 Combination

NO	C	NC	1	} Alarm Output Relay (/A3)
NO	C	NC	2	
NO	C	NC	3	
NO	C	NC	4	
NO	C	NC	5	
NO	C	NC	6	
①	②	③	} Remote Control (/R1)	
④	⑤	⊕		
SD Ⓐ	SD Ⓑ	SG		
RD Ⓐ	RD Ⓑ	FG	} Communication (RS-422A) (/C3)	

F01.EPS

**DIMENSION**

Unit: mm  
(approx. inch)

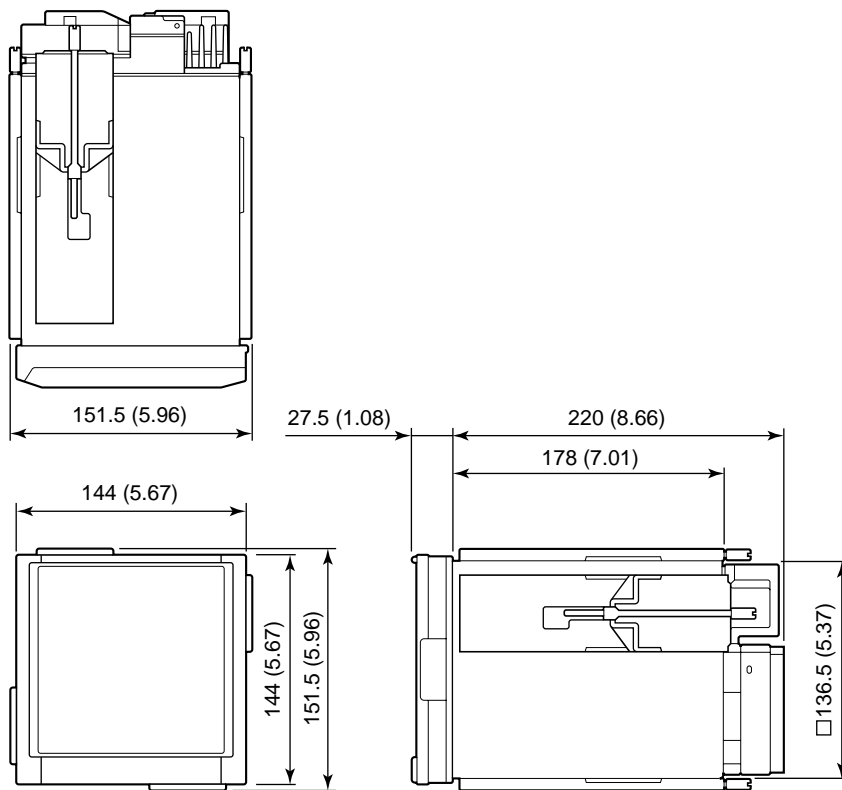
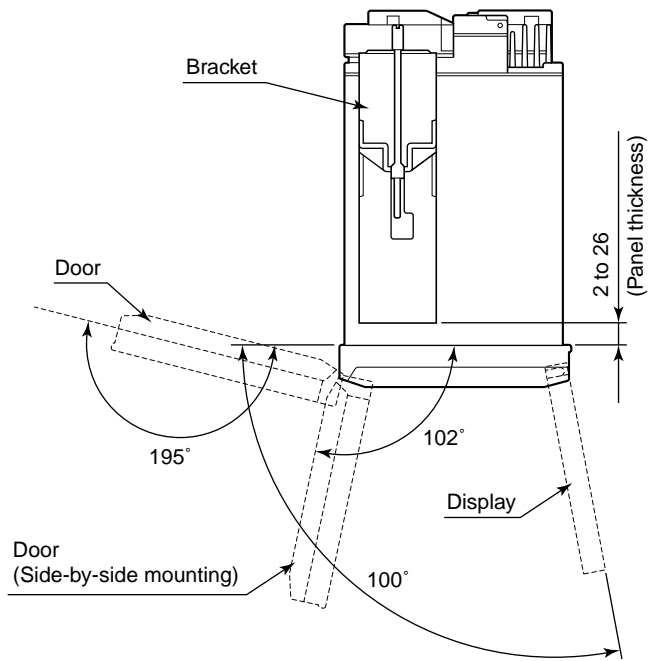

Note: If not specified, the tolerance is  $\pm 3\%$ .  
However, in cases of less than 10mm, the tolerance is  $\pm 0.3\text{mm}$ .

F02.EPS

**PANEL CUTOUT & SPACING**

Unit: mm  
(approx. inch)

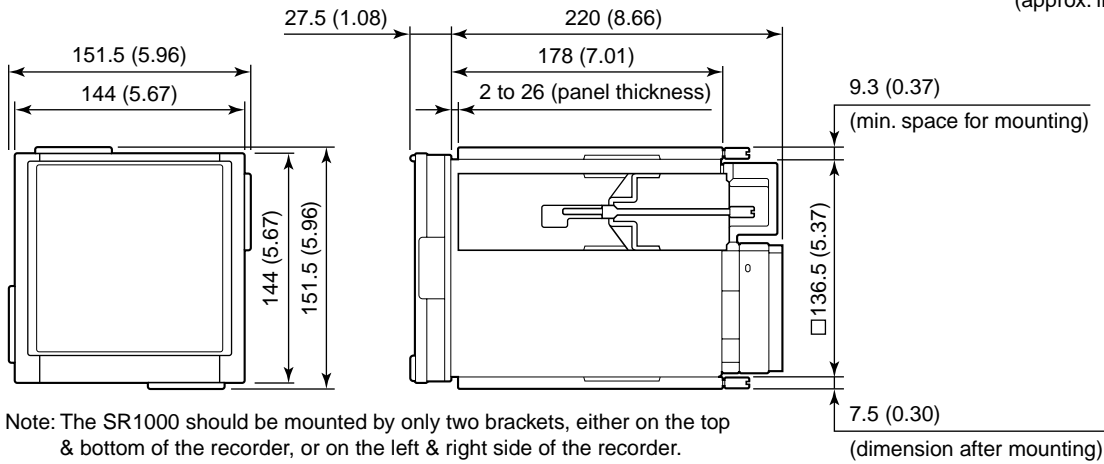

Note: The SR1000 should be mounted by only two brackets, either on the top & bottom of the recorder, or on the left & right side of the recorder.

Single-Unit Mounting

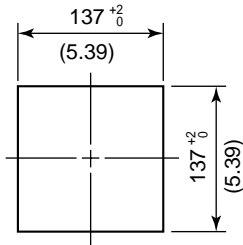

Side-by-Side Mounting (horizontally)

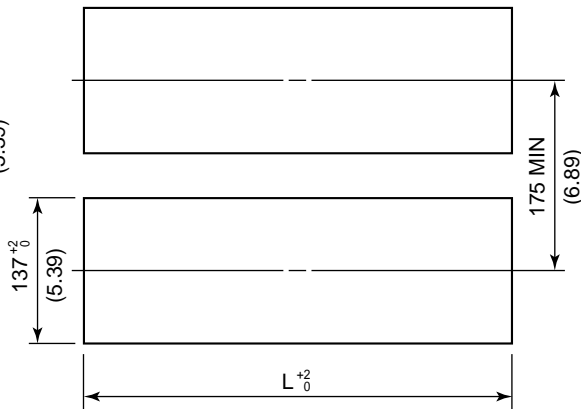

Side-by-Side Mounting (vertically max. 3 unit)

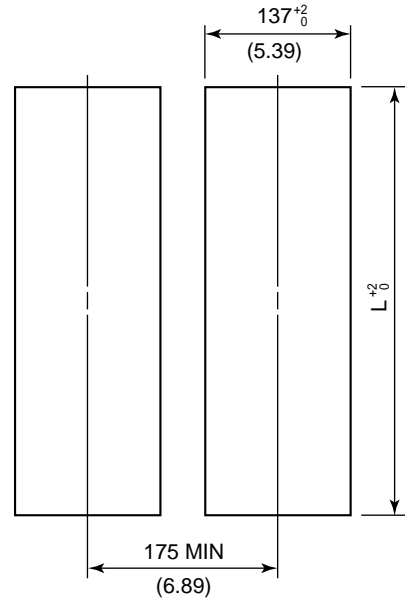

Units	$L_0^{+2}$ (mm)
2	282
3	426
4	570
5	714
6	858
7	1002
8	1146
9	1290
10	1434
n	$(144 \times n) - 6$

Weight:  
 SR1001-A-0: 3.1kg  
 SR1002-A-0: 3.3kg  
 SR1003-A-0: 3.5kg  
 SR1006-A-0: 3.4kg

Note: If not specified, the tolerance is  $\pm 3\%$ .  
 However, in cases of less than 10mm, the tolerance is  $\pm 0.3\text{mm}$ .

F03.EPS

**Relationship between Bezel Height of Peripheral Equipment and Space between Measurement Instruments**

**(In case mounted at the left side of SR1000)**

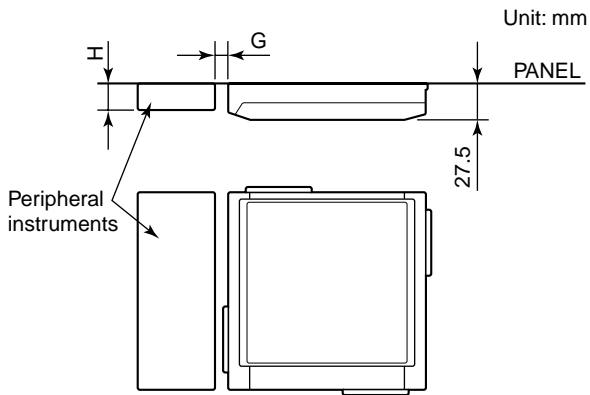

Height of Bezel from Panel Less than H (mm)	Space More than G (mm)
20	0
24	1
28	2
32	3
More than 36 unlimited	4

Note: For instruments which do not have taper and angle R.

F04.EPS

**(In case mounted at the right side of SR1000)**

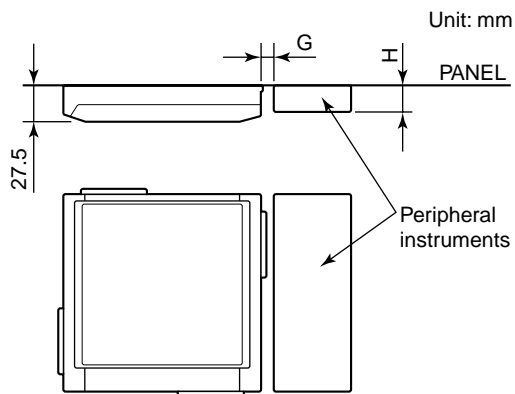

Height of Bezel from Panel; H (mm)	Space; G (mm)
less than 23.5	0
more than 23.5	more than 3

Note: For instruments which do not have taper and angle R.

F05.EPS